

VULCAN

CATALOG OF REPLACEMENT PARTS

GAS CONVECTION OVENS

MODELS

ML-126610	VC4GS
ML-126611	VC4GD
ML-136494	VC4GC
ML-126612	VC6GS
ML-126613	VC6GD
ML-136495	VC6GC



For additional information on Vulcan-Hart Company or to locate an authorized parts and service provider in your area, visit our website at www.vulcanequipment.com

Table of Contents

5	CONTROL PANEL (ML-126610, ML-126611, ML-126612, & ML-126613)
7	CONTROL PANEL (ML-136494 & ML-136495) (PREVIOUS)
9	CONTROL PANEL (ML-136494 & ML-136495) (CURRENT)
11	ELECTRICAL COMPONENT PANEL (WITHOUT ROAST & HOLD)
13	ELECTRICAL COMPONENT PANEL (WITH ROAST & HOLD)
15	SIMULTANEOUSLY OPENING DOORS (PREVIOUS CONSTRUCTION)
17	SIMULTANEOUSLY OPENING DOORS (CURRENT CONSTRUCTION)
19	INDEPENDENTLY OPENING DOORS (PREVIOUS CONSTRUCTION)
21	INDEPENDENTLY OPENING DOORS (CURRENT CONSTRUCTION)
23	OVEN PANELS AND MOTOR
25	OVEN PANELS AND RACK SUPPORTS
27	GAS PIPING AND FLAME CHAMBER (BEFORE SERIAL NUMBER)
29	GAS PIPING AND FLAME CHAMBER (AFTER SERIAL NUMBER)

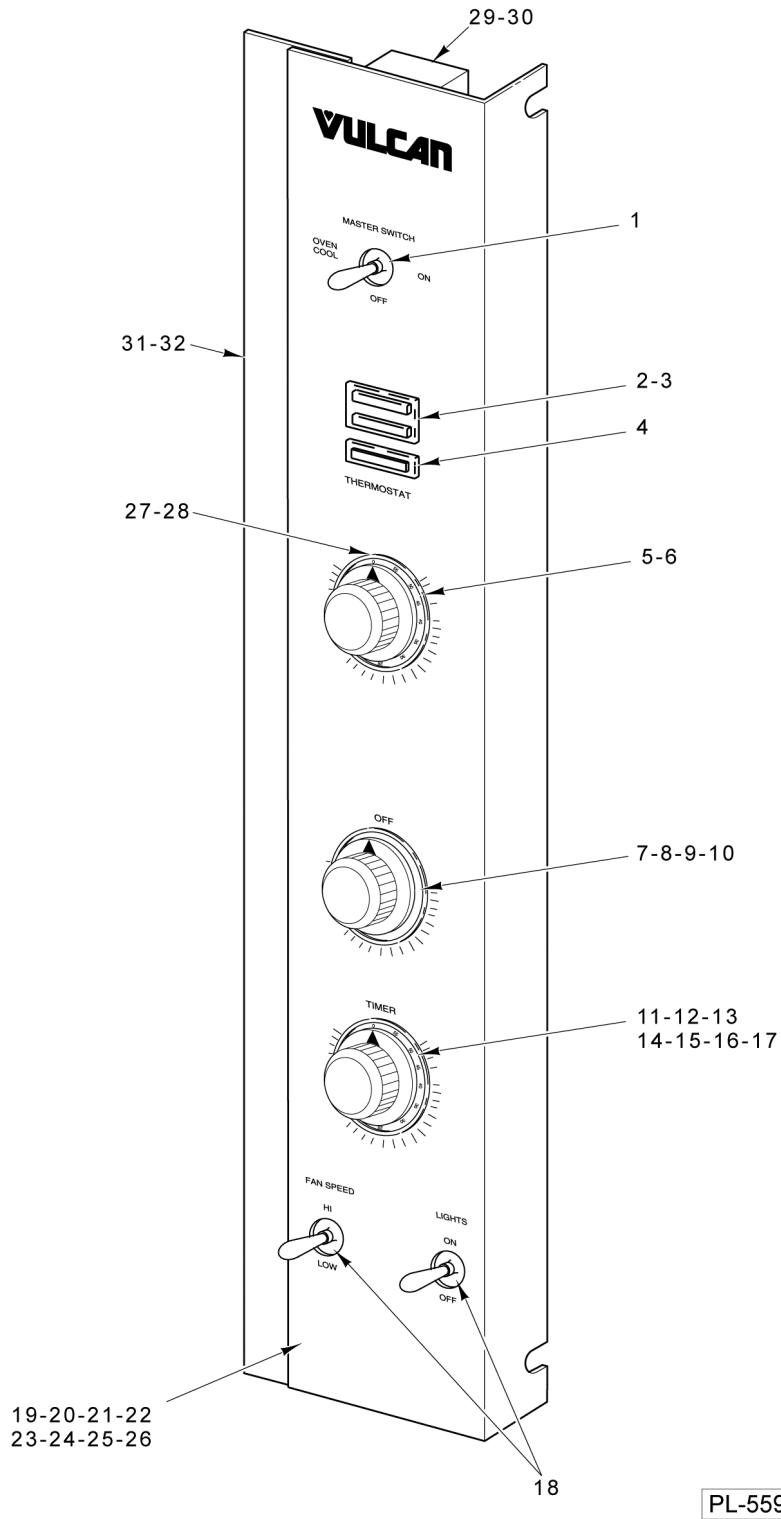

PL-55996

CONTROL PANEL
(ML-126610, ML-126611, ML-126612, & ML-126613)

CONTROL PANEL
(ML-126610, ML-126611, ML-126612, & ML-126613)

ILLUS. PL-55996	PART NO.	NAME OF PART	AMT.
1	00-340324-00008	Switch (4P.D.T.).....	1
2	00-913102-00163	Light - Indicator (Double) (120 V.).....	1
3	00-913102-00161	Light - Indicator (Double) (240 V.).....	1
4	00-354575-00004	Light - Indicator.....	1
5	00-411242-00001	Knob.....	1
6	00-913149	Kit - Temperature Control (With Harness).....	1
7	00-411242-00001	Knob.....	1
8	00-411690-00003	Timer (120 V.) (60 Hz.) (5-Hr.).....	1
9	00-411690-00004	Timer (240 V.) (60 Hz.) (5-Hr.).....	1
10	00-411690-00006	Timer (240 V.) (50 Hz.) (5-Hr.).....	1
11	00-411242-00001	Knob.....	1
12	00-411690-00001	Timer (120 V.) (60 Hz.) (1-Hr.).....	1
13	00-411690-00002	Timer (240 V.) (60 Hz.) (1-Hr.).....	1
14	00-411690-00003	Timer (120 V.) (60 Hz.) (5-Hr.).....	1
15	00-411690-00004	Timer (240 V.) (60 Hz.) (5-Hr.).....	1
16	00-411690-00005	Timer (240 V.) (50 Hz.) (1-Hr.).....	1
17	00-411690-00006	Timer (240 V.) (50 Hz.) (5-Hr.).....	1
18	00-340324-00009	Switch (D.P.D.T.).....	2
19	00-497280-00001	Overlay - Panel (1 Hr.) (D Models) (Without Roast & Hold).....	1
20	00-497284-00001	Overlay - Panel (5 Hr.) (D Models) (Without Roast & Hold).....	1
21	00-497285-00001	Overlay - Panel (1 Hr.) (D Models) (With Roast & Hold).....	1
22	00-497292-00001	Overlay - Panel (5 Hr.) (D Models) (With Roast & Hold).....	1
23	00-424201-00001	Overlay - Panel (1 Hr.) (S Models) (Without Roast & Hold).....	1
24	00-424237-00001	Overlay - Panel (5 Hr.) (S Models) (Without Roast & Hold).....	1
25	00-424211-00001	Overlay - Panel (1 Hr.) (S Models) (With Roast & Hold).....	1
26	00-424244-00001	Overlay - Panel (5 Hr.) (S Models) (With Roast & Hold).....	1
27	SC-114-82	Mach. Screw 4-40 x 5/16 Rd. Hd.....	2
28	WS-028-20	Washer (SST).....	2
29	00-411499-00003	Buzzer (230 V.).....	1
30	00-411499-00004	Buzzer (115 V.).....	1
31	00-424206-000G1	Panel - Control Weldment (Previous Construction).....	1
32	00-959489-000G1	Panel - Control Weldment (Current Construction).....	1

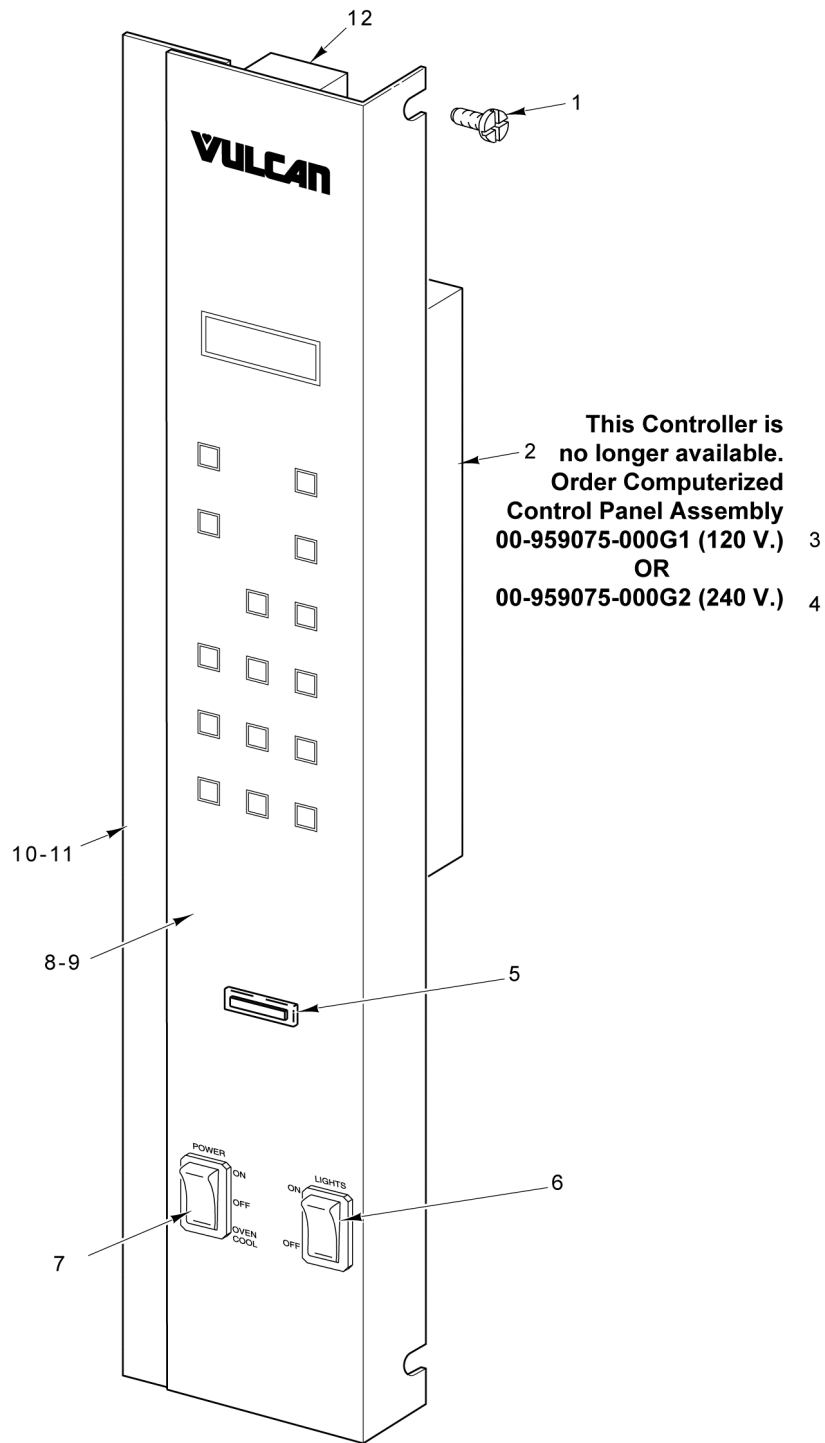

PL-60641

**CONTROL PANEL
(ML-136494 & ML-136495) (PREVIOUS)**

**CONTROL PANEL
(ML-136494 & ML-136495) (PREVIOUS)**

ILLUS.	PART NO.	NAME OF PART	AMT.
1	SD-037-02	Self-Tapping Screw 10-16 x 1/2 Hex Washer Hd., Type AB.....	3
*2		Controller.....	1
3	00-959075-000G1	Panel - Control Assy. (120 V.) (Complete).....	1
4	00-959075-000G2	Panel - Control Assy. (240 V.) (Complete).....	1
5	00-354575-00004	Light - Indicator.....	1
6	00-358628-00002	Switch - Rocker (2-Position).....	1
7	00-358628-00001	Switch - Rocker (3-Position).....	1
8	00-497506-00001	Overlay - Control Panel (Previous Construction).....	1
9	00-497506-00001	Overlay - Control Panel (Current Construction).....	1
10	00-424842-000G1	Panel - Weldment (Previous Construction).....	1
11	00-499301-000G1	Panel - Control Assy. (Current Construction).....	1
12	00-423918-00001	Electronic Beeper.....	1

* (No Longer Available, order Item 3 or 4.)

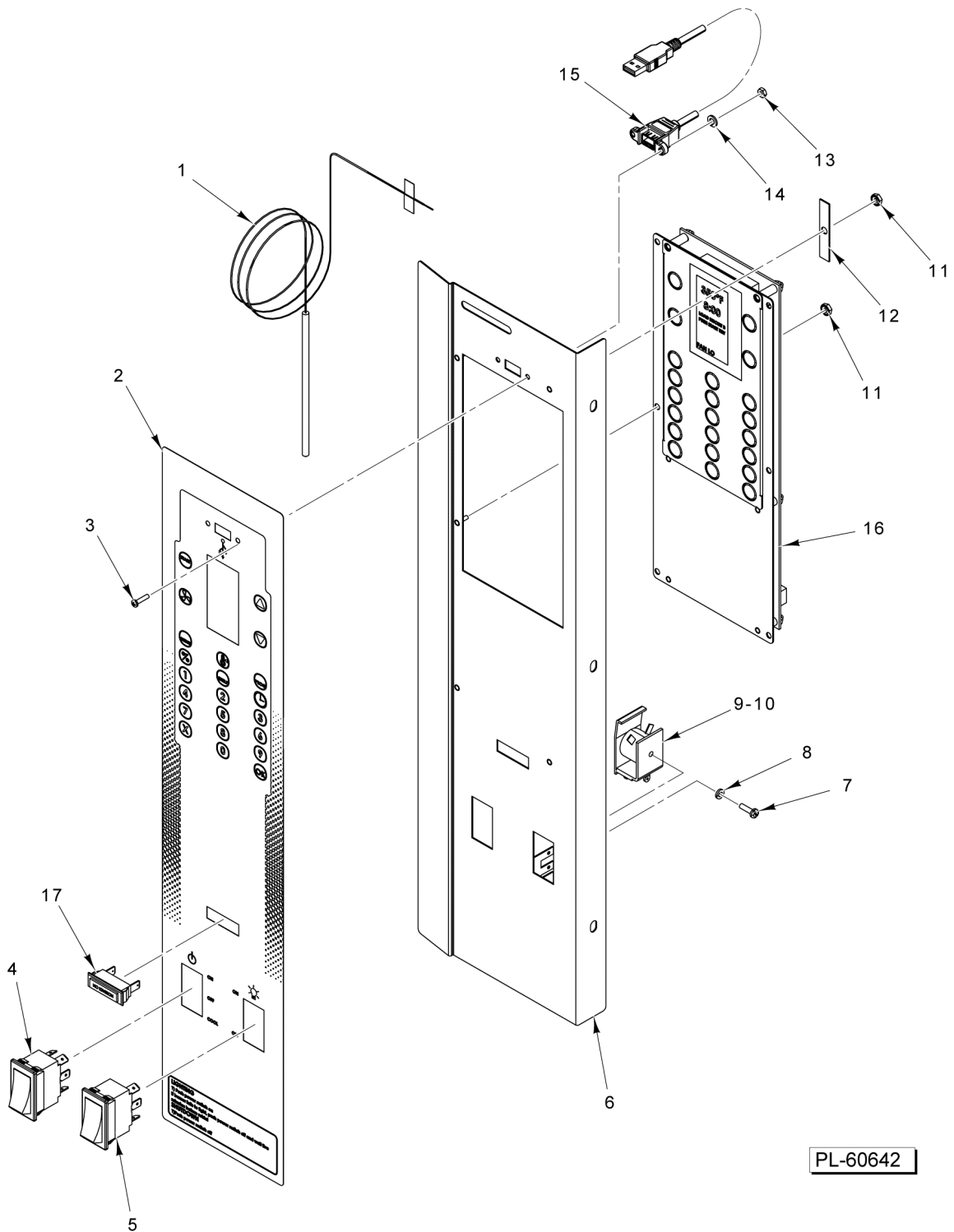

PL-60642

**CONTROL PANEL
(ML-136494 & ML-136495) (CURRENT)**

**CONTROL PANEL
(ML-136494 & ML-136495) (CURRENT)**

ILLUS. PL-60642	PART NO.	NAME OF PART	AMT.
1	00-920883-00003	Probe - Temperature.....	1
2	00-959113-00001	Overlay (Vulcan).....	1
3		Mach. Screw 4-40 x 1/2 Phil. Pan Hd.....	2
4	00-358628-00001	Switch - Rocker (3-Position).....	1
5	00-358628-00002	Switch - Rocker (2-Position).....	1
6	00-959074	Penel - Weldment.....	1
7	SC-114-83	Mach. Screw 6-32 x 1/4 Slotted Pan Hd. (SST).....	1
8	WL-003-12	Lockwasher #8 Helical.....	1
9	00-411499-00003	Buzzer (230 V.).....	1
10	00-411499-00004	Buzzer (115 V.).....	1
11	NS-046-89	Nut Assy. 6-32 Hex.....	AR
12	00-959110-00001	Plate.....	2
13		Nut 4-40 Hex.....	2
14		Lockwasher.....	2
15	00-959000-000G1	Cable Assy. (USB) (1 Ft.) (Incls. Items 3, 14, & 15).....	1
16	00-959077-00001	Controller - Cooking (NCC).....	1
17	00-354575-00004	Light - Indicator.....	1

41 00-353589-00001 Probe - Temp 43 00-423813-00003 Wire - Ignition
 42 00-920883-00003 Probe - Temp 44 00-428428-000G1 Wire - Sensor

PARTS NOT ILLUSTRATED

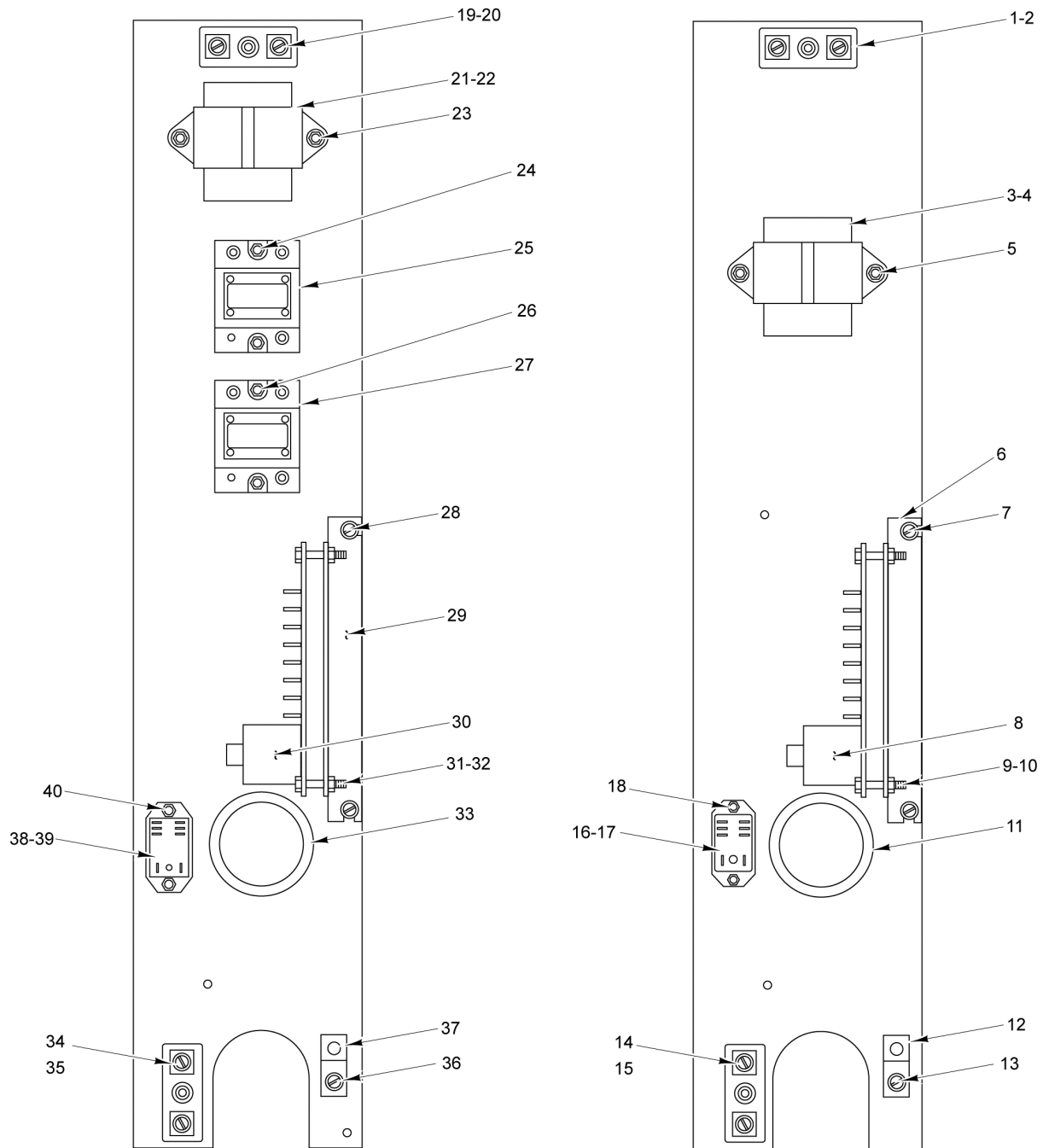

VC4GC / VC6GC

**VC4GD / VC6GD
 WITHOUT ROAST & HOLD**

PL-55994

**ELECTRICAL COMPONENT PANEL
 (WITHOUT ROAST & HOLD)**

ELECTRICAL COMPONENT PANEL (WITHOUT ROAST & HOLD)

ILLUS. PL-55994	PART NO.	NAME OF PART	AMT.
1	00-417934-000G1	Block Assy. - Porcelain.....	1
2	SD-034-52	Self-Tapping Screw 8-32 x 1 Hex Washer Hd., Type T.....	1
3	00-411500-00012	Transformer (120 V.) (24 V. Output).....	1
4	00-411500-00013	Transformer (208-240 V.) (24 V. Output).....	1
5	SD-032-07	Self-Tapping Screw 10-24 x 1/2 Hex Washer Hd., Type TT.....	2
6	00-423760-00001	Bracket - Ignition Module.....	1
7	SD-032-07	Self-Tapping Screw 10-24 x 1/2 Hex Washer Hd., Type TT.....	1
8	00-424137-00002	Control - Spark Ignition.....	1
9	SD-034-52	Self-Tapping Screw 8-32 x 1 Hex Washer Hd., Type T.....	2
10	NS-044-07	Nut Assy. 8-32 Hex Keps.....	2
11	FE-024-23	Bushing - Electrical (Snap).....	1
12	00-417856-00001	Lug - Grounding (With Set Screw).....	1
13	SD-032-07	Self-Tapping Screw 10-24 x 1/2 Hex Washer Hd., Type TT.....	1
14	00-417934-000G1	Block Assy. - Porcelain.....	1
15	SD-034-52	Self-Tapping Screw 8-32 x 1 Hex Washer Hd., Type T.....	1
16	00-416535-00006	Relay - Heating (120 V.).....	1
17	00-416535-00007	Relay - Heating (200-240 V.).....	1
18	SD-034-49	Self-Tapping Screw 8-32 x 1/2 Hex Washer Hd., Type T.....	1
19	00-417934-000G1	Block Assy. - Porcelain.....	1
20	SD-034-52	Self-Tapping Screw 8-32 x 1 Hex Washer Hd., Type T.....	1
21	00-421758-000G1	Transformer (120 V.) (24 V. Output).....	1
22	00-421758-000G2	Transformer (208-240 V.) (24 V. Output).....	1
23	SD-032-07	Self-Tapping Screw 10-24 x 1/2 Hex Washer Hd., Type TT.....	2
24	SD-034-52	Self-Tapping Screw 8-32 x 1 Hex Washer Hd., Type T.....	4
25	00-821875-00002	Relay - Solid State (50 Amp.).....	2
26	SD-034-52	Self-Tapping Screw 8-32 x 1 Hex Washer Hd., Type T.....	4
27	00-821875-00002	Relay - Solid State (50 Amp.).....	2
28	SD-032-07	Self-Tapping Screw 10-24 x 1/2 Hex Washer Hd., Type TT.....	1
29	00-423760-00001	Bracket - Ignition Module.....	1
30	00-424137-00002	Control - Spark Ignition.....	1
31	SD-034-52	Self-Tapping Screw 8-32 x 1 Hex Washer Hd., Type T.....	2
32	NS-044-07	Nut Assy. 8-32 Hex Keps.....	2
33	FE-024-23	Bushing - Electrical (Snap).....	1
34	SD-034-52	Self-Tapping Screw 8-32 x 1 Hex Washer Hd., Type T.....	1
35	00-417934-000G1	Block Assy. - Porcelain.....	1
36	SD-032-07	Self-Tapping Screw 10-24 x 1/2 Hex Washer Hd., Type TT.....	1
37	00-417856-00001	Lug - Grounding (With Set Screw).....	1
38	00-416535-00006	Relay - Heating (120 V.).....	1
39	00-416535-00007	Relay - Heating (200-240 V.).....	1
40	SD-034-49	Self-Tapping Screw 8-32 x 1/2 Hex Washer Hd., Type T.....	2
41	00-353589-00001	Probe Temperature (SST).....	1
42	00-920883-00003	Probe - Temperature.....	1
43	00-423813-00003	Wire - Ignition (High Voltage).....	1
44	00-428428-000g1	Wire Assy - Flame Sensor.....	1

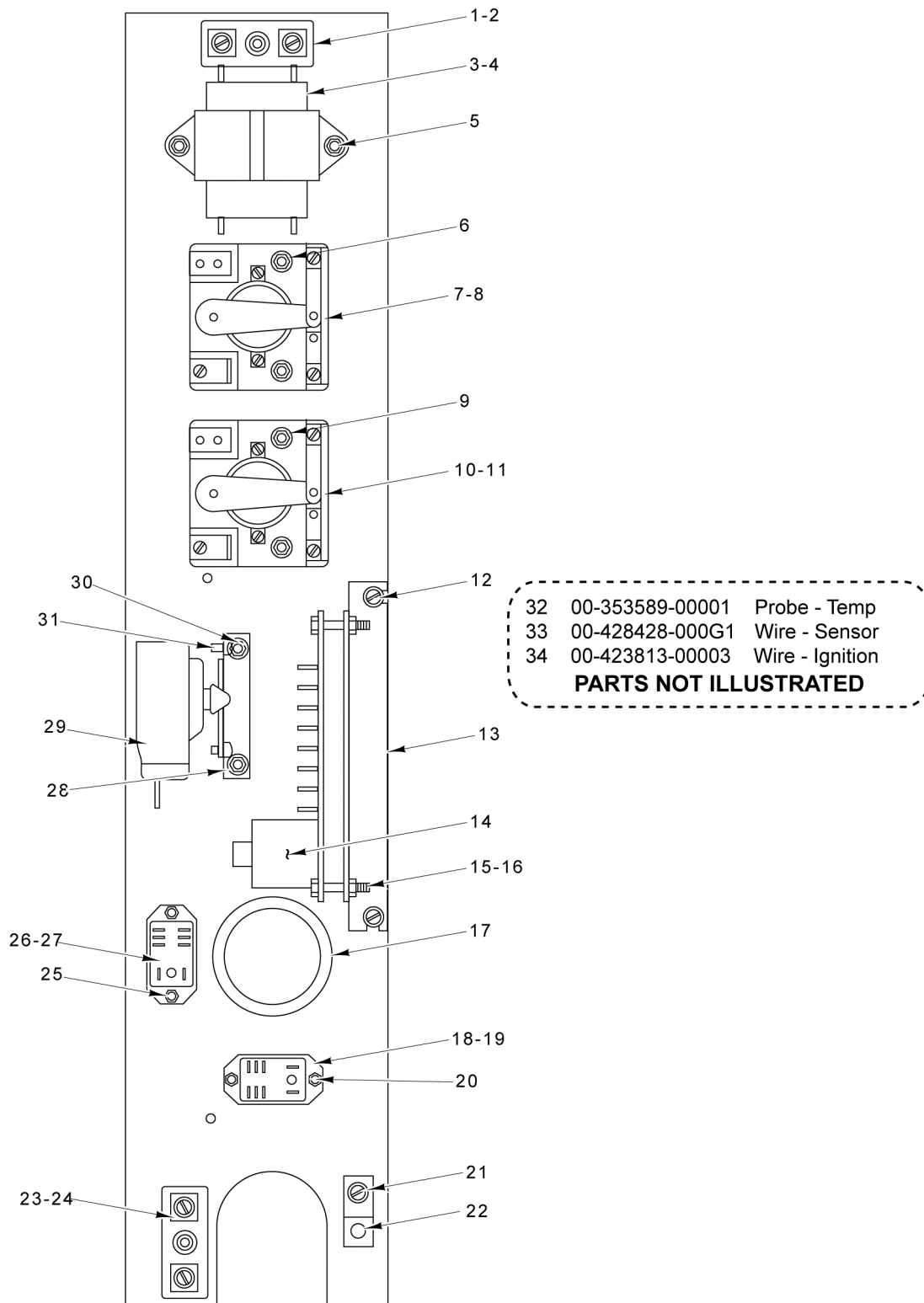

WITH ROAST & HOLD

PL-55995

**ELECTRICAL COMPONENT PANEL
(WITH ROAST & HOLD)**

ELECTRICAL COMPONENT PANEL (WITH ROAST & HOLD)

ILLUS. PL-55995	PART NO.	NAME OF PART	AMT.
1	00-417934-000G1	Block Assy. - Porcelain.....	1
2	SD-034-52	Self-Tapping Screw 8-32 x 1 Hex Washer Hd., Type T.....	1
3	00-421758-000G1	Transformer (120 V.) (24 V. Output).....	1
4	00-421758-000G2	Transformer (208-240 V.) (24 V. Output).....	1
5	SD-032-07	Self-Tapping Screw 10-24 x 1/2 Hex Washer Hd., Type TT.....	2
6	SD-034-52	Self-Tapping Screw 8-32 x 1 Hex Washer Hd., Type T.....	2
7	00-411497-000A1	Relay (1-Pole) (120 V.).....	1
8	00-411497-000A2	Relay (1-Pole) (200 V.).....	1
9	SD-034-52	Self-Tapping Screw 8-32 x 1 Hex Washer Hd., Type T.....	2
10	00-411497-000A1	Relay (1-Pole) (120 V.).....	1
11	00-411497-000A2	Relay (1-Pole) (200 V.).....	1
12	SD-032-07	Self-Tapping Screw 10-24 x 1/2 Hex Washer Hd., Type TT.....	2
13	00-423760-00001	Bracket - Ignition Module.....	1
14	00-424137-00002	Control - Spark Ignition.....	1
15	SD-034-52	Self-Tapping Screw 8-32 x 1 Hex Washer Hd., Type T.....	2
16	NS-044-07	Nut Assy. 8-32 Hex Keps.....	2
17	FE-024-23	Bushing - Electrical (Snap).....	1
18	00-416535-00006	Relay - Heating (120 V.).....	1
19	00-416535-00007	Relay - Heating (200-240 V.).....	1
20	SD-034-49	Self-Tapping Screw 8-32 x 1/2 Hex Washer Hd., Type T.....	2
21	SD-032-07	Self-Tapping Screw 10-24 x 1/2 Hex Washer Hd., Type TT.....	1
22	00-417856-00001	Lug - Grounding (With Set Screw).....	1
23	00-417934-000G1	Block Assy. - Porcelain.....	1
24	SD-034-52	Self-Tapping Screw 8-32 x 1 Hex Washer Hd., Type T.....	1
25	SD-034-49	Self-Tapping Screw 8-32 x 1/2 Hex Washer Hd., Type T.....	2
26	00-416535-00006	Relay - Heating (120 V.).....	1
27	00-416535-00007	Relay - Heating (200-240 V.).....	1
28	00-424832-00001	Bracket - Mounting.....	1
29	00-413764-00001	Thermostat.....	1
30	SD-032-07	Self-Tapping Screw 10-24 x 1/2 Hex Washer Hd., Type TT.....	2
31	SC-114-83	Mach. Screw 6-32 x 1/4 Slotted Pan Hd. (SST).....	2
32	00-353589-00001	Probe Temperature (SST).....	1
33	00-428428-000g1	Wire Assy - Flame Sensor.....	1
34	00-423813-00003	Wire - Ignition (High Voltage).....	1

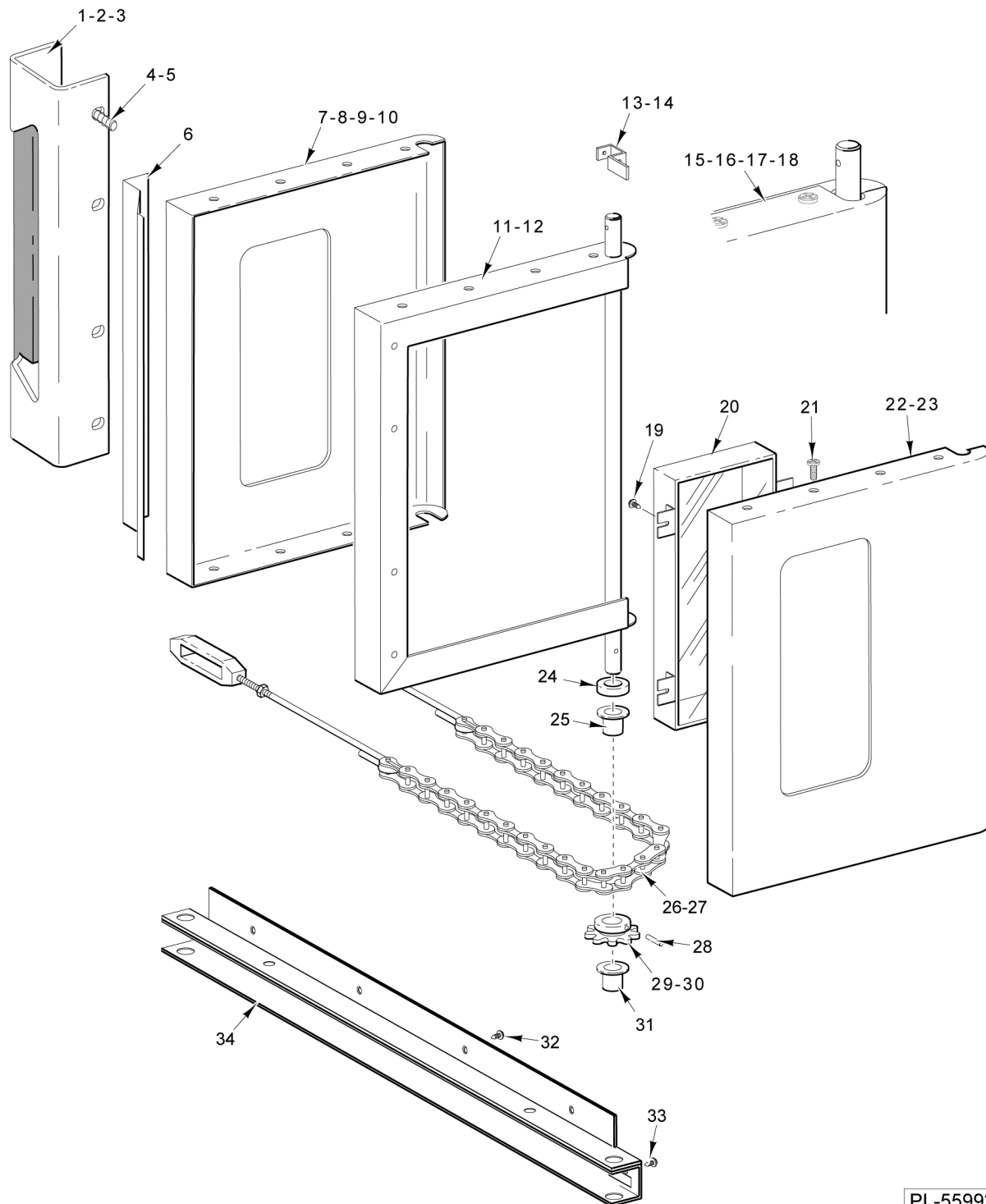

PL-55992

**SIMULTANEOUSLY OPENING DOORS
(PREVIOUS CONSTRUCTION)**

**SIMULTANEOUSLY OPENING DOORS
(PREVIOUS CONSTRUCTION)**

ILLUS. PL-55992	PART NO.	NAME OF PART	AMT.
1	00-356562-00001	Handle - Door.....	1
2	00-421923-000G1	Grip - Set.....	1
3	SC-113-98	Mach. Screw 10-24 x 1/2 Hex Washer Hd.....	3
4	SC-041-01	Cap Screw 1/4-20 x 3/4 Hex Hd. (SST).....	4
5	WL-019-18	Lockwasher 1/4 Light.....	4
6	00-356550-00001	Latch - Friction.....	1
7	00-421913-00002	Panel - Outer Door (RH) (W/O Window).....	1
8	00-421913-00003	Panel - Outer Door (LH) (W/Window).....	1
9	00-421913-00001	Panel - Outer Door (RH) (W/Window).....	1
10	00-421913-00004	Panel - Outer Door (LH) (W/O Window).....	1
11	00-421904-000G2	Frame Assy. - Door (LH).....	1
12	00-421905-000G1	Frame Assy. - Door (RH).....	1
13	00-424163-00001	Lever - Door Switch.....	1
14	SD-034-52	Self-Tapping Screw 8-32 x 1 Hex Washer Hd., Type T.....	1
15	00-424730-00001	Door Assy. (LH) (W/Window).....	1
16	00-424730-00002	Door Assy. (LH) (W/O Window).....	1
17	00-424731-00001	Door Assy. (RH) (W/Window).....	1
18	00-424731-00002	Door Assy. (RH) (W/O Window).....	1
19	SD-034-62	Self-Tapping Screw 10-32 x 1/2 Hex Washer Hd., Type T.....	4
20	00-358534-00001	Window Assy.....	1
21	SD-034-22	Self-Tapping Screw 10-16 X 5/8 Phil. Truss Hd., Type AB.....	9
22	00-358532-00001	Panel - Inner Door (W/Window).....	1
23	00-358533-00003	Panel - Inner Door (W/O Window).....	1
24	00-343143-00002	Washer.....	2
25	00-347080-00002	Bearing - Door Shaft.....	2
26	00-343608-00002	Door Chain & Turnbuckle Assy.....	2
27	00-352667-00001	Cable - Door Stop.....	1
28	PS-004-11	Spirol Pin 3/16 x 1-1/4 Heavy.....	2
29	00-342166-00001	Sprocket - Door Shaft.....	2
30	SC-047-28	Set Screw 1/4-28 x 3/8 Hex Hdls., Cup Pt.....	2
31	00-347080-00002	Bearing - Door Shaft.....	2
32	SC-022-40	Mach. Screw 1/4-20 x 3/4 Phil. Flat Hd. (SST).....	4
33	SC-113-90	Mach. Screw 1/4-20 x 3/4 Hex Hd.....	2
34	00-357846-00001	Channel - Door Sill Weldment.....	1

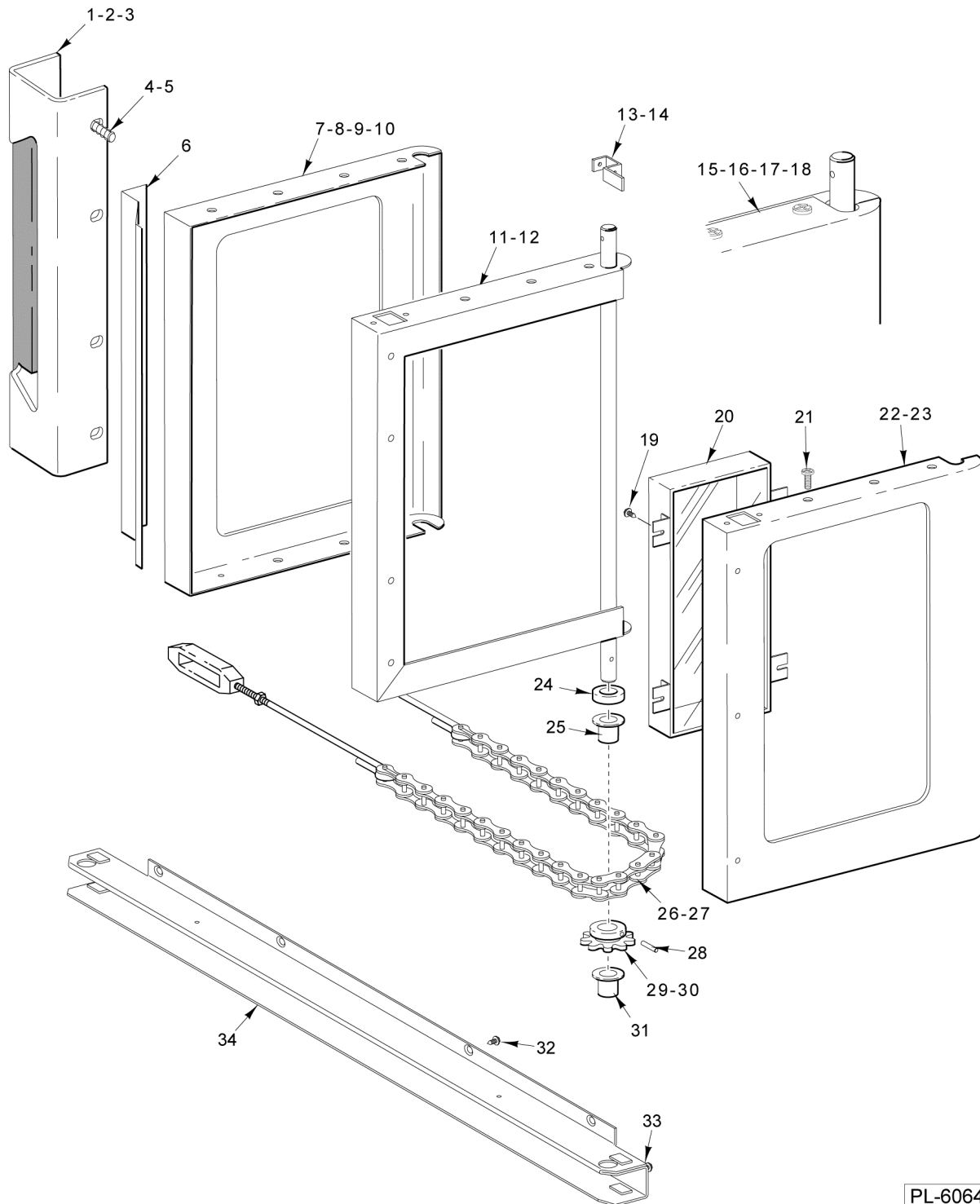

PL-60644

**SIMULTANEOUSLY OPENING DOORS
(CURRENT CONSTRUCTION)**

SIMULTANEOUSLY OPENING DOORS (CURRENT CONSTRUCTION)

ILLUS. PL-60644	PART NO.	NAME OF PART	AMT.
1	00-356562-00001	Handle - Door.....	1
2	00-421923-000G1	Grip - Set.....	1
3	SC-113-98	Mach. Screw 10-24 x 1/2 Hex Washer Hd.....	3
4	SC-041-01	Cap Screw 1/4-20 x 3/4 Hex Hd. (SST).....	4
5	WL-019-18	Lockwasher 1/4 Light.....	4
6	00-356550-00001	Latch - Friction.....	1
7	00-421913-00002	Panel - Outer Door (RH) (W/O Window).....	1
8	00-421913-00003	Panel - Outer Door (LH) (W/Window).....	1
9	00-421913-00001	Panel - Outer Door (RH) (W/Window).....	1
10	00-421913-00004	Panel - Outer Door (LH) (W/O Window).....	1
11	00-421904-000G2	Frame Assy. - Door (LH).....	1
12	00-421905-000G1	Frame Assy. - Door (RH).....	1
13	00-424163-00001	Lever - Door Switch.....	1
14	SD-034-52	Self-Tapping Screw 8-32 x 1 Hex Washer Hd., Type T.....	1
15	00-499289-000G1	Door Assy. (LH) (W/Window).....	1
16	00-499289-000G2	Door Assy. (LH) (W/O Window).....	1
17	00-499290-000G1	Door Assy. (RH) (W/Window).....	1
18	00-499290-000G2	Door Assy. (LH) (W/O Window).....	1
19	SD-034-62	Self-Tapping Screw 10-32 x 1/2 Hex Washer Hd., Type T.....	4
20	00-358534-00001	Window Assy.....	1
21	SD-034-22	Self-Tapping Screw 10-16 X 5/8 Phil. Truss Hd., Type AB.....	9
22	00-358532-00001	Panel - Inner Door (W/Window).....	1
23	00-358533-00003	Panel - Inner Door (W/O Window).....	1
24	00-343143-00002	Washer.....	2
25	00-347080-00002	Bearing - Door Shaft.....	2
26	00-343608-00002	Door Chain & Turnbuckle Assy.....	2
27	00-352667-00001	Cable - Door Stop.....	1
28	PS-004-11	Spirol Pin 3/16 x 1-1/4 Heavy.....	2
29	00-342166-00001	Sprocket - Door Shaft.....	2
30	SC-047-28	Set Screw 1/4-28 x 3/8 Hex Hdls., Cup Pt.....	2
31	00-347080-00002	Bearing - Door Shaft.....	2
32	SC-022-40	Mach. Screw 1/4-20 x 3/4 Phil. Flat Hd. (SST).....	4
33	SC-113-90	Mach. Screw 1/4-20 x 3/4 Hex Hd.....	2
34	00-499300-000G1	Channel - Bottom Door Sill.....	1

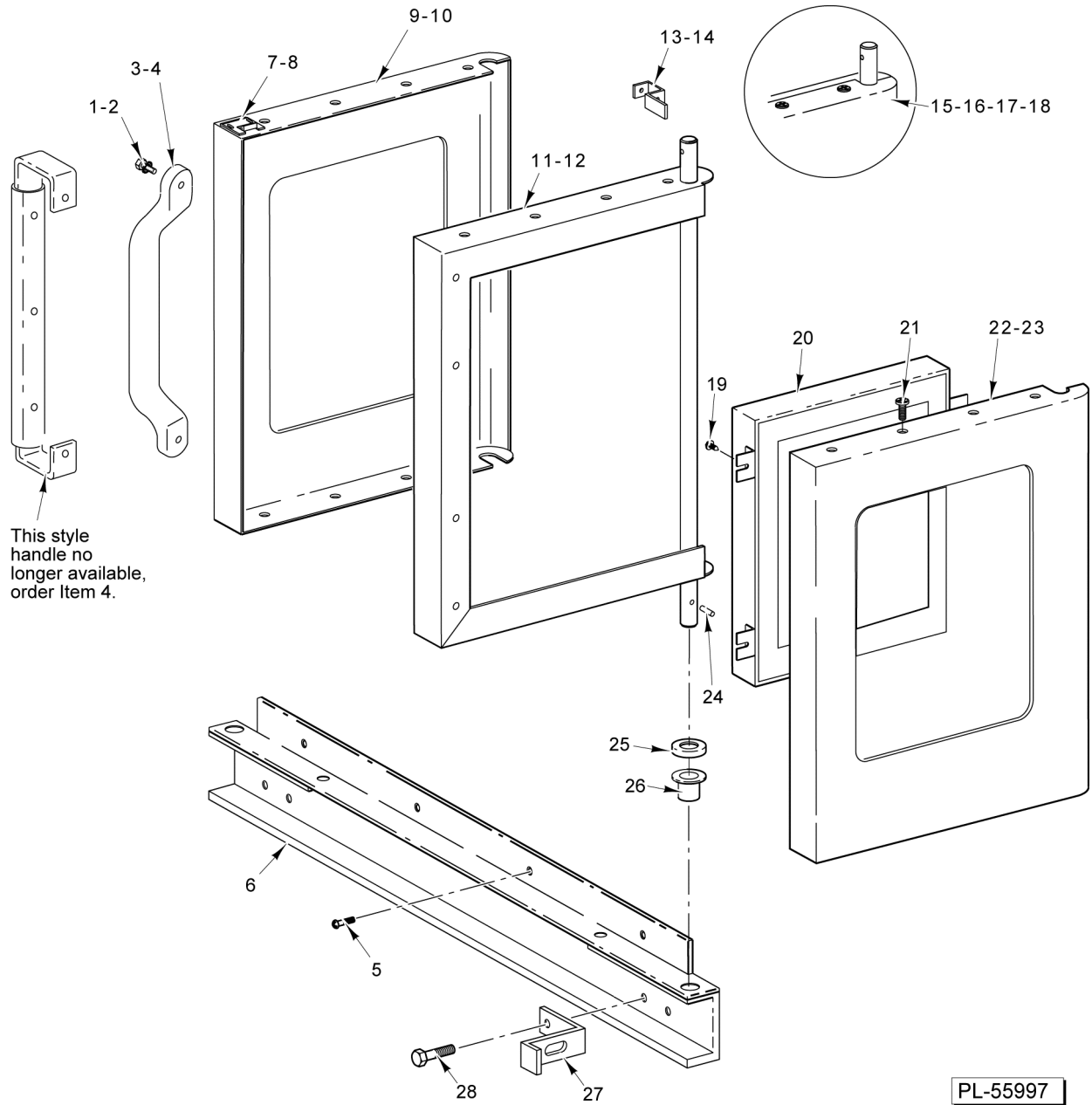

**INDEPENDENTLY OPENING DOORS
(PREVIOUS CONSTRUCTION)**

INDEPENDENTLY OPENING DOORS (PREVIOUS CONSTRUCTION)

ILLUS. PL-55997	PART NO.	NAME OF PART	AMT.
1	00-959087-00001	Screw 1/4-20 x 1-1/4 Black Hd.....	2
2	WL-013-14	Lockwasher 1/4 Internal Shakeproof.....	2
3	00-957108-00001	Handle - Molded (Black).....	1
4	00-913102-00179	Kit - Handle.....	1
5	SC-022-40	Mach. Screw 1/4-20 x 3/4 Phil. Flat Hd. (SST).....	4
6	00-357846-00001	Channel - Door Sill Weldment.....	1
7	00-423847-00001	Strike - Door.....	1
8	SD-034-22	Self-Tapping Screw 10-16 X 5/8 Phil. Truss Hd., Type AB.....	2
9	00-358600-00001	Panel - Outer Door (RH) (W/Window).....	1
10	00-358600-00002	Panel - Outer Door (RH) (W/O Window).....	1
11	00-421905-000G1	Frame Assy. - Door (RH).....	1
12	00-421904-000G2	Frame Assy. - Door (LH).....	1
13	00-424163-00001	Lever - Door Switch.....	1
14	SD-034-52	Self-Tapping Screw 8-32 x 1 Hex Washer Hd., Type T.....	1
15	00-358529-00005	Door Assy. (LH) (W/Window).....	1
16	00-358529-00006	Door Assy. (LH) (W/O Window).....	1
17	00-358530-00003	Door Assy. (RH) (W/Window).....	1
18	00-358530-00004	Door Assy. (RH) (W/O Window).....	1
19	SD-034-62	Self-Tapping Screw 10-32 x 1/2 Hex Washer Hd., Type T.....	4
20	00-358534-00001	Window Assy.....	1
21	SD-034-22	Self-Tapping Screw 10-16 X 5/8 Phil. Truss Hd., Type AB.....	8
22	00-358532-00001	Panel - Inner Door (W/Window).....	1
23	00-358533-00003	Panel - Inner Door (W/O Window).....	1
24	PS-004-11	Spirol Pin 3/16 x 1-1/4 Heavy.....	1
25	00-343143-00002	Washer.....	2
26	00-347080-00002	Bearing - Door Shaft.....	1
27	00-424158-00001	Door Stop.....	1
28	SC-113-90	Mach. Screw 1/4-20 x 3/4 Hex Hd.....	2

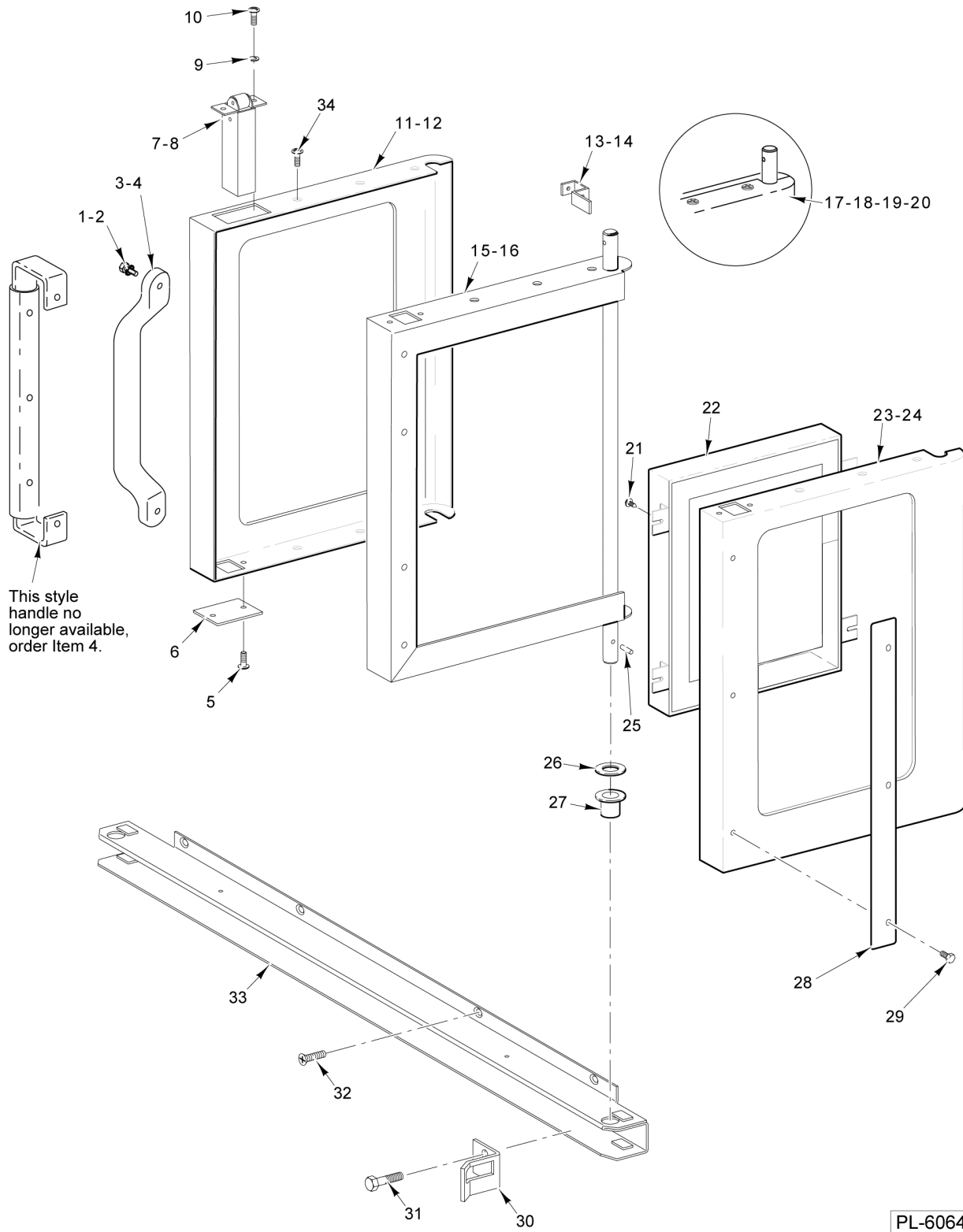

**INDEPENDENTLY OPENING DOORS
(CURRENT CONSTRUCTION)**

INDEPENDENTLY OPENING DOORS (CURRENT CONSTRUCTION)

ILLUS. PL-60645	PART NO.	NAME OF PART	AMT.
1	00-959087-00001	Screw 1/4-20 x 1-1/4 Black Hd.....	2
2	WL-013-14	Lockwasher 1/4 Internal Shakeproof.....	2
3	00-957108-00001	Handle - Molded (Black).....	1
4	00-913102-00179	Kit - Handle.....	1
5	SD-034-22	Self-Tapping Screw 10-16 X 5/8 Phil. Truss Hd., Type AB.....	2
6	00-499264-00001	Plate - Latch Cutout.....	1
7	00-497586-00001	Latch - Door Roller.....	1
8	00-347545-00001	Catch Assy. - Door (Ball Style) (Not Shown).....	1
9	WL-019-35	Lockwasher #10 Internal.....	2
10	SC-117-73	Mach. Screw 10-32 x 5/8 Phil. Truss Hd.....	2
11	00-358600-00001	Panel - Outer Door (RH) (W/Window).....	1
12	00-358600-00002	Panel - Outer Door (RH) (W/O Window).....	1
13	00-424163-00001	Lever - Door Switch.....	1
14	SD-034-52	Self-Tapping Screw 8-32 x 1 Hex Washer Hd., Type T.....	1
15	00-421905-000G1	Frame Assy. - Door (RH).....	1
16	00-421904-000G2	Frame Assy. - Door (LH).....	1
17	00-499285-000G1	Door Assy. (LH) (W/Window).....	1
18	00-499285-000G2	Door Assy. (LH) (W/O Window).....	1
19	00-499286-000G1	Door Assy. (RH) (W/Window).....	1
20	00-499286-000G2	Door Assy. (RH) (W/O Window).....	1
21	SD-034-62	Self-Tapping Screw 10-32 x 1/2 Hex Washer Hd., Type T.....	4
22	00-358534-00001	Window Assy.....	1
23	00-358532-00001	Panel - Inner Door (W/Window).....	1
24	00-358533-00003	Panel - Inner Door (W/O Window).....	1
25	PS-004-11	Spirol Pin 3/16 x 1-1/4 Heavy.....	1
26	00-343143-00002	Washer.....	2
27	00-347080-00002	Bearing - Door Shaft.....	1
28	00-357837-00001	Seal - Door End.....	1
29	SD-034-22	Self-Tapping Screw 10-16 X 5/8 Phil. Truss Hd., Type AB.....	3
30	00-499263-00001	Door Stop.....	1
31	SC-113-90	Mach. Screw 1/4-20 x 3/4 Hex Hd.....	2
32	SC-022-40	Mach. Screw 1/4-20 x 3/4 Phil. Flat Hd. (SST).....	4
33	00-499300-000G1	Channel - Bottom Door Sill.....	1
34	SD-034-22	Self-Tapping Screw 10-16 X 5/8 Phil. Truss Hd., Type AB.....	2

40	00-427617-00001	Flue - Deflector	48	00-343634-00002	Caster
41	00-959663-00001	Tube - Snorkel Assy.	49	00-357047-00001	Caster - Swivel
42	00-402558-00004	Clip - Bulb	50	00-357047-00002	Caster - Swivel
43	00-424172-00001	Leg - Set (PTD)	51	00-417063-00001	Strap
44	00-424172-00002	Leg - Set (SST)	52	00-357093-00001	Ring - Locking
45	00-424157-000G7	Leg (PTD)	53	00-288946-00002	Foot
46	00-342150-00005	Leg (For Double Stack)	54	SC-113-76	Screw
47	00-343634-00001	Caster	55	00-425428-00001	Foot (Adjustable)

PARTS NOT ILLUSTRATED

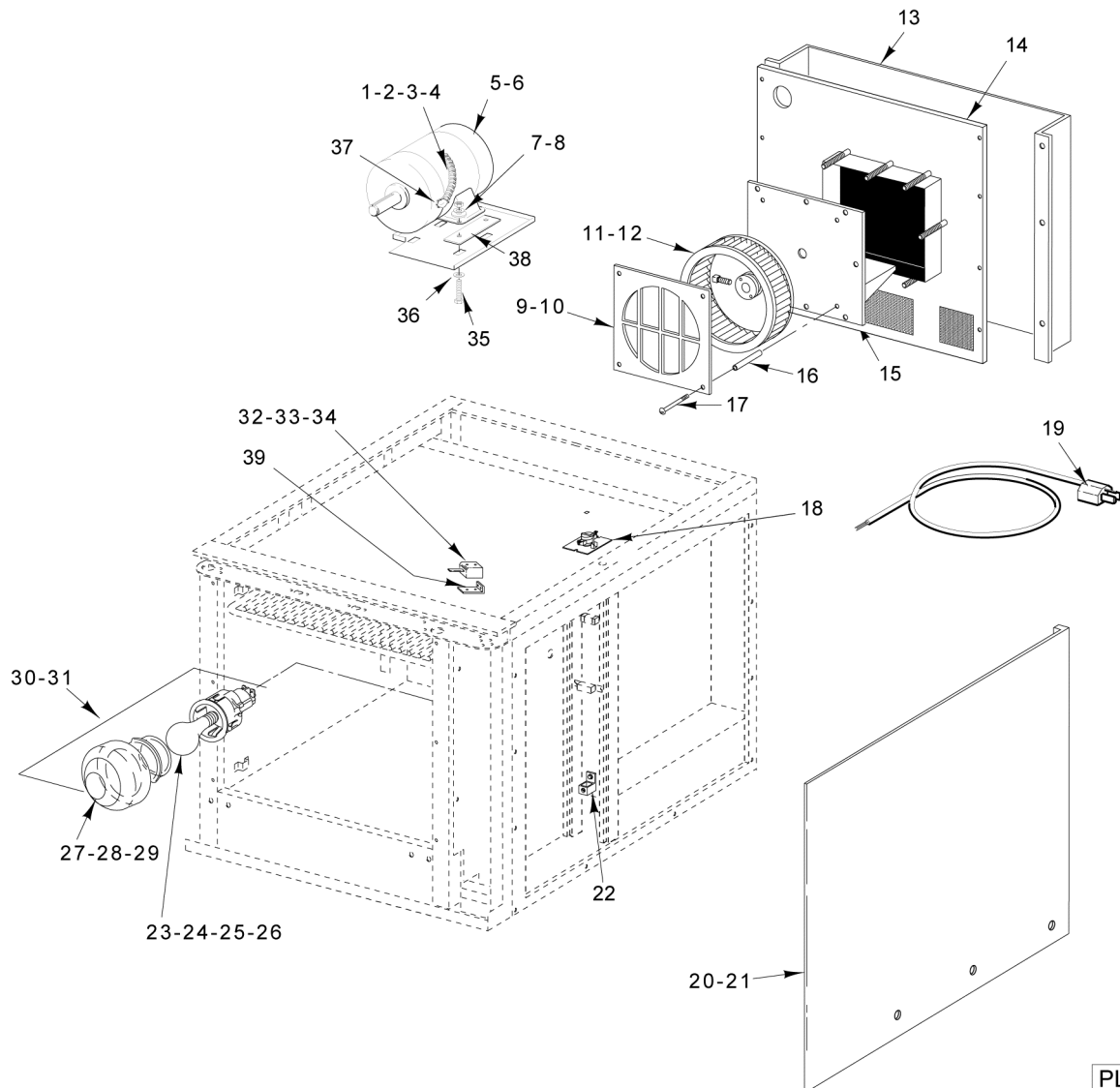

PL-55991

OVEN PANELS AND MOTOR

OVEN PANELS AND MOTOR

ILLUS.	PART NO.	NAME OF PART	AMT.
PL-55991-1			
1	FE-006-05	Lock Nut 1/2	1
2	00-414540-00B35	Conduit 3/8 x 35 In. Lg.....	1
3	00-342285-00001	Bushing - Plastic.....	2
4	FE-002-03	Connector - Conduit 3/8 TS Straight.....	1
5	00-358516-00001	Motor 1/2 Hp. (2-Speed) (115 V., 50/60 Hz., 1 Ph.).....	1
6	00-358516-00002	Motor 1/2 Hp. (2-Speed) (208-240 V., 50/60 Hz., 1 Ph.).....	1
7	WS-029-46	Washer.....	4
8	NS-046-86	Nut Assy. 5/16-18 KEPS Hex.....	4
9	00-411136-00003	Cover - Fan (50 Hz.).....	1
10	00-411136-00004	Cover - Fan (60 Hz.).....	1
11	00-415780-00003	Wheel - Blower (60 Hz.).....	1
12	00-415780-00005	Wheel - Blower (50 Hz.).....	1
13	00-424840-00002	Panel - Back (SST) (Optional).....	1
14	00-424153-000G1	Panel Assy. - Back.....	1
15	00-423289-000G1	Motor Mount.....	1
16	00-411289-00004	Spacer - Fan Housing.....	4
17	SC-120-15	Mach. Screw 1/4-20 x 4 Rd. Hd.....	4
18	00-958827-000G3	Kit - Oven Limit Assy.....	1
19	00-405016-00001	Cord - Electric Supply (120 V. Only).....	1
20	00-424140-00002	Panel - Outer (RH) (SST) (VC4G).....	1
21	00-424228-00002	Panel - Outer (RH) (SST) (VC6G).....	1
22	00-417856-00001	Lug - Grounding (With Set Screw).....	1
23	01-1000V7-00028	Bulb (120 V.) (Previous Construction).....	1
24	00-357036-00001	Oven Lamp (40 Watts) (120-130 V.) (Current Construction).....	1
25	00-342766-00002	Light Bulb - Oven (40 Watts) (240 V.) (Previous Construction).....	1
26	00-913102-00032	Kit - Lamp & Housing (250 V.) (Current Construction).....	1
27	00-423832-00001	Cover - Light (Previous Construction).....	2
28	01-1000V7-00027	Lamp - Oven (Complete) (Lens, Base, & Bulb) (Current Construction).....	1
29	00-357036-00003	Lens - Lamp.....	1
30	00-357036-00001	Oven Lamp (40 Watts) (120-130 V.).....	2
31	00-913102-00032	Kit - Lamp & Housing (250 V.).....	2
32	00-411496-000F1	Switch - Micro (Units Builts Before 5/12/09).....	1
33	00-499310-000G1	Micro Switch Kit (Units Builts After 5/12/09).....	1
34	SD-034-47	Self-Tapping Screw 6-32 x 1 Hex Washer Hd., Type T.....	2
35	SC-113-65	Cap Screw 5/16-18 x 1-1/4 Hex Hd.....	4
36	WS-029-46	Washer.....	4
37	FE-002-52	Connector - Conduit 3/8 TS 90 Degree.....	1
38	00-358723-00001	Spacer - Steel.....	2
39	00-425324-00001	Bracket - Door Switch.....	1
40	00-427617-00001	Flue - Deflector.....	1
41	00-959663-00001	Tube - Snorkel.....	1
42	00-402558-00004	Clip - Tubing.....	2
43	00-424172-00001	Leg - Set (25-3/4 In.) (PTD).....	1
44	00-424172-00002	Leg - Set (25-3/4 In.) (SST).....	1
45	00-424157-000G7	Leg Assembly for Caster and Foot (Painted Black).....	4
46	00-342150-00005	Leg (8 In.) (Double Stack).....	4
47	00-343634-00001	Caster (With Brake).....	2
48	00-343634-00002	Caster (Without Brake).....	2
49	00-357047-00001	Caster - Swivel (Without Brake).....	2
50	00-357047-00002	Caster - Swivel (With Brake).....	2
51	00-417063-00001	Strap - Tie Down.....	4
52	00-357093-00001	Ring - Locking (Use with Item 45).....	4
53	00-288946-00002	Foot - Adjustable (1-5/8) (SST) (Use with Item 45).....	4
54	SC-113-76	Cap Screw 1/4-20 x 1 Hex Hd (Use with legs).....	16
55	00-425428-00001	Foot - Adjustable (Use with Item 46).....	4

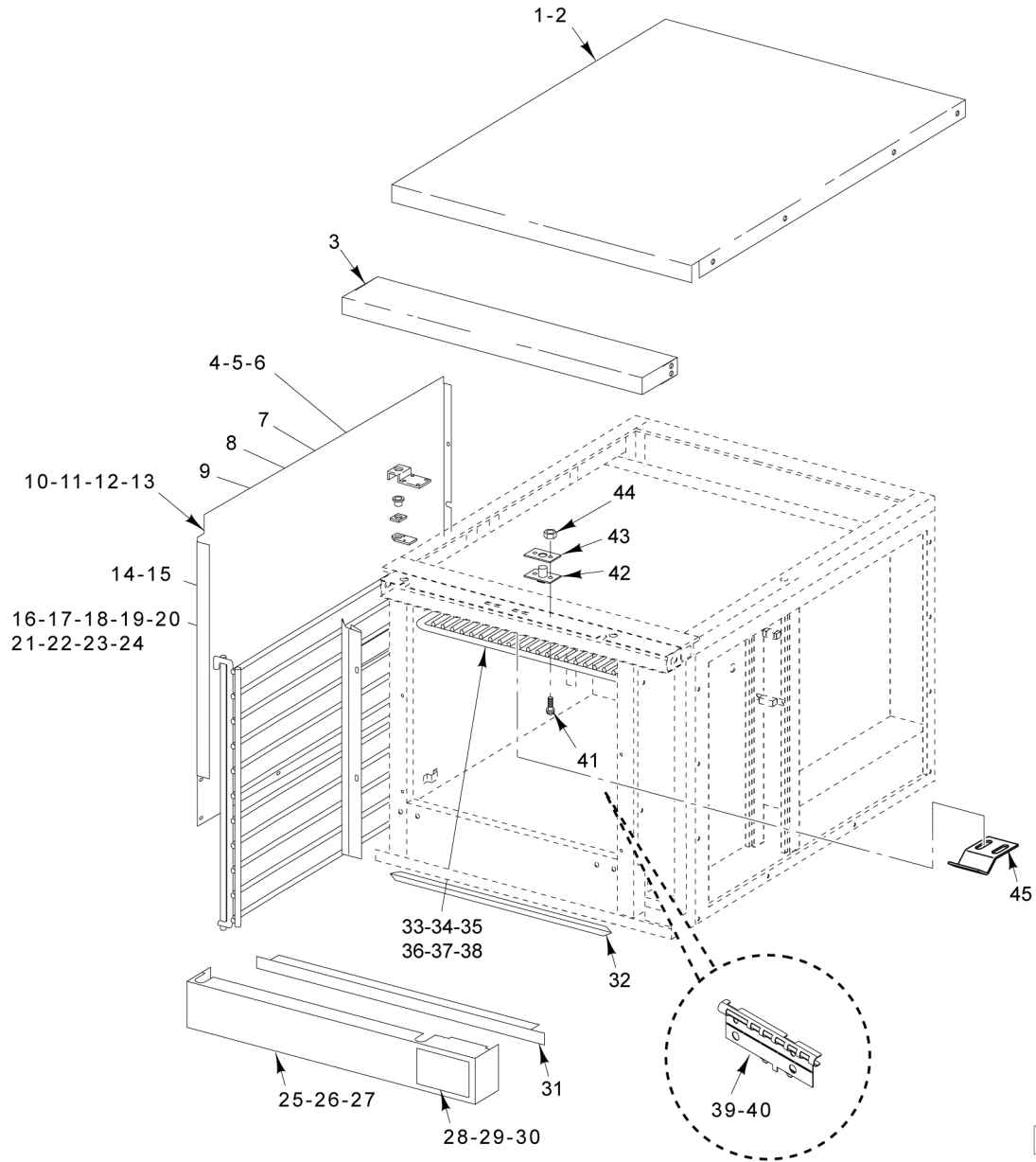

PL-55998

OVEN PANELS AND RACK SUPPORTS

OVEN PANELS AND RACK SUPPORTS

ILLUS. PL-55998	PART NO.	NAME OF PART	AMT.
1	00-424141-00002	Top (SST) (ML-126614, ML-126615, & ML-126616).....	1
2	00-424229-00002	Top (SST) (ML-126618 & ML-126619).....	1
3	00-421799-00001	Top - Front.....	1
4	00-353484-00001	Plate - Retainer.....	2
5	SC-053-41	Mach. Screw 1/4-20 x 1/2 Slotted Truss Hd. (SST).....	4
6	NS-038-08	Lock Nut 1/4-20 x 1 Hex.....	4
7	00-347080-00002	Bearing - Door Shaft.....	2
8	00-353482-00001	Spacer.....	2
9	00-353483-00001	Plate - Upper Door Bearing.....	2
10	00-424142-00002	Panel - Outer (SST) (LH) (ML-126614, ML-126615, & ML-126616) (Previous Construction).....	1
11	00-424230-00002	Panel - Outer (SST) (LH) (ML-126618 & ML-126619) (Previous Construction).....	1
12	00-499302-00001	Side - Left Body (ML-126614, ML-126615, & ML-126616) (Current Construction).....	1
13	00-499303-00001	Side - Left Body (ML-126618 & ML-126619) (Current Construction).....	1
14	00-357919-00001	Kit - Door Seal (Incls. Items 15 & 32).....	1
15	00-423842-000G1	Seal - Vertical Door (Set) (LH & RH).....	1
16	00-428104-00001	Guide - Rack (LH) (ML-126614, ML-126615, & ML-126616) (Before S/N481809325).....	1
17	00-428104-00002	Guide - Rack (RH) (ML-126614, ML-126615, & ML-126616) (Before S/N481809325).....	1
18	00-428104-00003	Guide - Rack (LH) (ML-126618 & ML-126619) (Before S/N481809325).....	1
19	00-428104-00004	Guide - Rack (RH) (ML-126618 & ML-126619) (Before S/N481809325).....	1
20	00-342141-00001	Rack - Support (LH) (ML-126614, ML-126615, & ML-126616) (Previous Construction).....	1
21	00-342141-00002	Rack - Support (RH) (ML-126614, ML-126615, & ML-126616) (Previous Construction).....	1
22	00-424833-00001	Rack - Support (LH) (ML-126618 & ML-126619) (Previous Construction).....	1
23	00-424833-00002	Rack - Support (RH) (ML-126618 & ML-126619) (Previous Construction).....	1
24	00-959456-00001	Rack - Guide Common (Starting S/N481809325).....	2
25	00-423766-000G1	Trim - Bottom W/Access Door Assy. (Previous Construction).....	1
26	00-421797-00002	Trim - Bottom (Previous Construction).....	1
27	00-499261-00002	Trim - Bottom W/O Access Door Assy. (Current Construction).....	1
28	00-423758-00001	Door - Access Trim (Previous Construction).....	1
29	00-499297-00001	Door - Lower Access Trim.....	1
30	00-425199-00001	Fastener - Nylon (Push-In).....	2
31	00-424865-00001	Cover - Trim.....	1
32	00-357507-00001	Seal - Horizontal Door (30-1/2 In. Long) (Top & Bottom).....	2
33	00-411265-00011	Rack Assy. (ML-126614, ML-126615, & ML-126616) (Single Center Cross Member) (Used Before 9/09).....	AR
34	00-411265-00022	Rack Assy. (ML-126614, ML-126615, & ML-126616) (Two Cross Members) (Used from 9/09 to S/N481809325).....	AR
35	00-959523-00001	Rack Assy. (ML-126614, ML-126615, & ML-126616) (Starting S/N481809554).....	AR
36	00-411265-00010	Rack Assy. (ML-126618 & ML-126619) (Single Center Cross Member) (Used Before 9/09).....	AR
37	00-411265-00020	Rack Assy. (ML-126618 & ML-126619) (Two Cross Members) (Used from 9/09 to S/N481809325).....	AR
38	00-959523-00002	Rack Assy. (ML-126618 & ML-126619) (Starting S/N481809554).....	AR
39	00-959753-00001	Probe Guard & Retainer.....	1
40	SD-032-07	Self-Tapping Screw 10-24 x 1/2 Hex Washer Hd., Type TT.....	2
41	SC-115-51	Mach. Screw 10-32 x 1/2 Phil. Truss Hd.....	2
42	00-347545-00001	Catch Assy. - Door (Previous Construction).....	1
43	00-423848-00001	Shim - Door Strike (Previous Construction).....	AR
44	NS-038-03	Lock Nut 10-32 SP (Previous Construction).....	2
45	00-497585-00001	Plate - Strike (Current Construction).....	1

USED ON OVENS BEFORE THE FOLLOWING S/N

VC4GD(NAT)	S/N481835388
VC4GD(LP)	S/N481835394
VC6GD(NAT)	S/N481835406
VC6GD(LP)	S/N481835429
VC4GD(NAT)	S/N541077665
VC4GD(LP)	S/N541077965

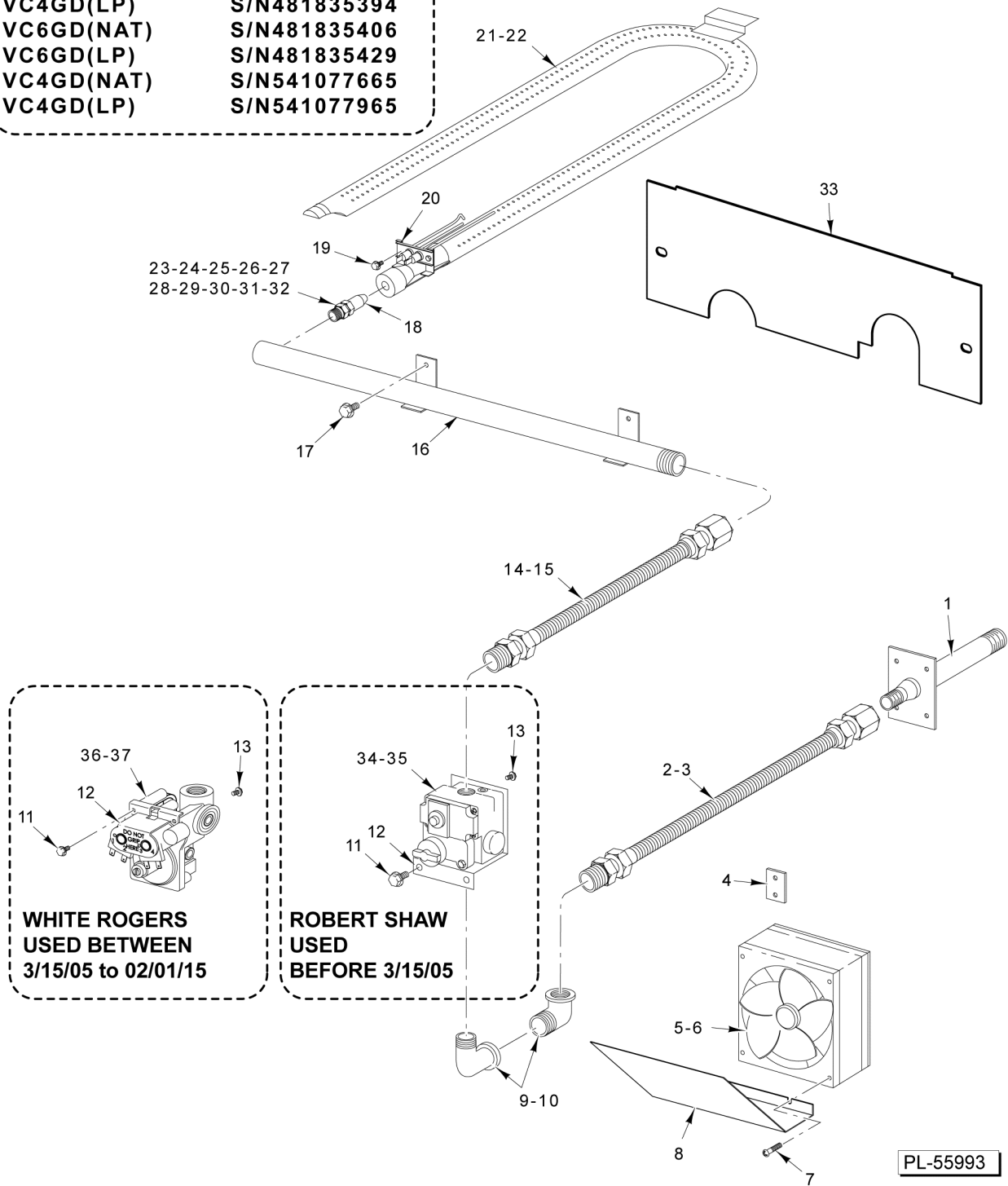

**GAS PIPING AND FLAME CHAMBER
(BEFORE SERIAL NUMBER)**

**GAS PIPING AND FLAME CHAMBER
(BEFORE SERIAL NUMBER)**

ILLUS. PL-55993	PART NO.	NAME OF PART	AMT.
1	00-423819-00003	Pipe - Weldment Gas Inlet.....	1
2	00-423828-00001	Tube - Flex (30 In.) (1/2 Male End) (Used with Items 34 & 35).....	1
3	00-423828-00006	Tube - Flex (30 In.) (3/8 Male End) (Used with Items 36 & 37).....	1
4	00-425433-00001	Fan - Clip.....	1
5	00-424940-00001	Fan - Cooling (120 V.).....	1
6	00-424940-00002	Fan - Cooling (230 V.).....	1
7	SD-034-52	Self-Tapping Screw 8-32 x 1 Hex Washer Hd., Type T.....	2
8	00-423820-00001	Deflector - Air.....	1
9	FP-013-17	Elbow - Street 1/2 x 90 Deg. (Used with Items 34 & 35).....	2
10	FP-078-75	Elbow - Pipe 3/8 x 90 Deg. (Used with Items 36 & 37).....	1
11	SC-113-80	Cap Screw 1/4-20 x 1/2 Hex Hd.....	2
12	00-424728-00001	Bracket - Gas Valve.....	1
13	SC-117-60	Mach. Screw 10-32 x 1-1/4 Phil. Oval Hd.....	2
14	00-423828-00002	Tube - Flex (18 In.) (1/2 Male End) (Used with Items 34 & 35).....	1
15	00-423828-00007	Tube - Flex (18 In.) (3/8 Male End) (Used with Items 36 & 37).....	1
16	00-424138-00001	Manifold.....	1
17	SC-113-80	Cap Screw 1/4-20 x 1/2 Hex Hd.....	2
18	00-417879-00001	Nozzle - Pilot Burner.....	1
19	SD-034-49	Self-Tapping Screw 8-32 x 1/2 Hex Washer Hd., Type T.....	2
20	00-424194-00001	Ignitor - Flame Detector.....	1
21	00-424135-000G1	Burner Assy. (VC4G).....	1
22	00-424195-000G1	Burner Assy. (VC6G).....	1
23	00-010901-00031	Orifice - Spud (31 Drill) (NAT) (Sea Level to 2499 Ft.).....	1
24	00-010901-00032	Orifice - Spud (32 Drill) (NAT) (2500 Ft. to 3499 Ft.).....	1
25	00-010901-00033	Orifice - Spud (33 Drill) (NAT) (3500 Ft. to 4499 Ft.).....	1
26	00-010901-00034	Orifice - Spud (34 Drill) (NAT) (4500 Ft. to 6499 Ft.).....	1
27	00-010901-00035	Orifice - Spud (35 Drill) (NAT) (6500 Ft. to 8499 Ft.).....	1
28	00-010901-00036	Orifice - Spud (36 Drill) (NAT) (8500 Ft. to 10500 Ft.).....	1
29	00-010901-00046	Orifice - Spud (46 Drill) (LP) (Sea Level to 2499 Ft.).....	1
30	00-010901-00048	Orifice - Spud (48 Drill) (LP) (2500 Ft. to 4499 Ft.).....	1
31	00-010901-00049	Orifice - Spud (49 Drill) (LP) (4500 Ft. to 7499 Ft.).....	1
32	00-010901-00050	Orifice - Spud (50 Drill) (LP) (7500 Ft. to 10500 Ft.).....	1
33	00-424191-000G1	Cover - Burner Access.....	1
34	00-410841-00018	Valve - Gas Control (NAT) (Robert Shaw) (Before February 2005).....	1
35	00-410841-00019	Valve - Gas Control (LP) (Robert Shaw) (Before February 2005).....	1
36	00-497269-00001	Valve - Gas Control (NAT) (White Rogers) (From February 2005 to February 2015).....	1
37	00-497269-00002	Valve - Gas Control (LP) (White Rogers) (From February 2005 to February 2015).....	1

USED ON OVENS AFTER THE FOLLOWING S/N

VC4GD(NAT)	S/N481835388
VC4GD(LP)	S/N481835394
VC6GD(NAT)	S/N481835406
VC6GD(LP)	S/N481835429
VC4GD(NAT)	S/N541077665
VC4GD(LP)	S/N541077965

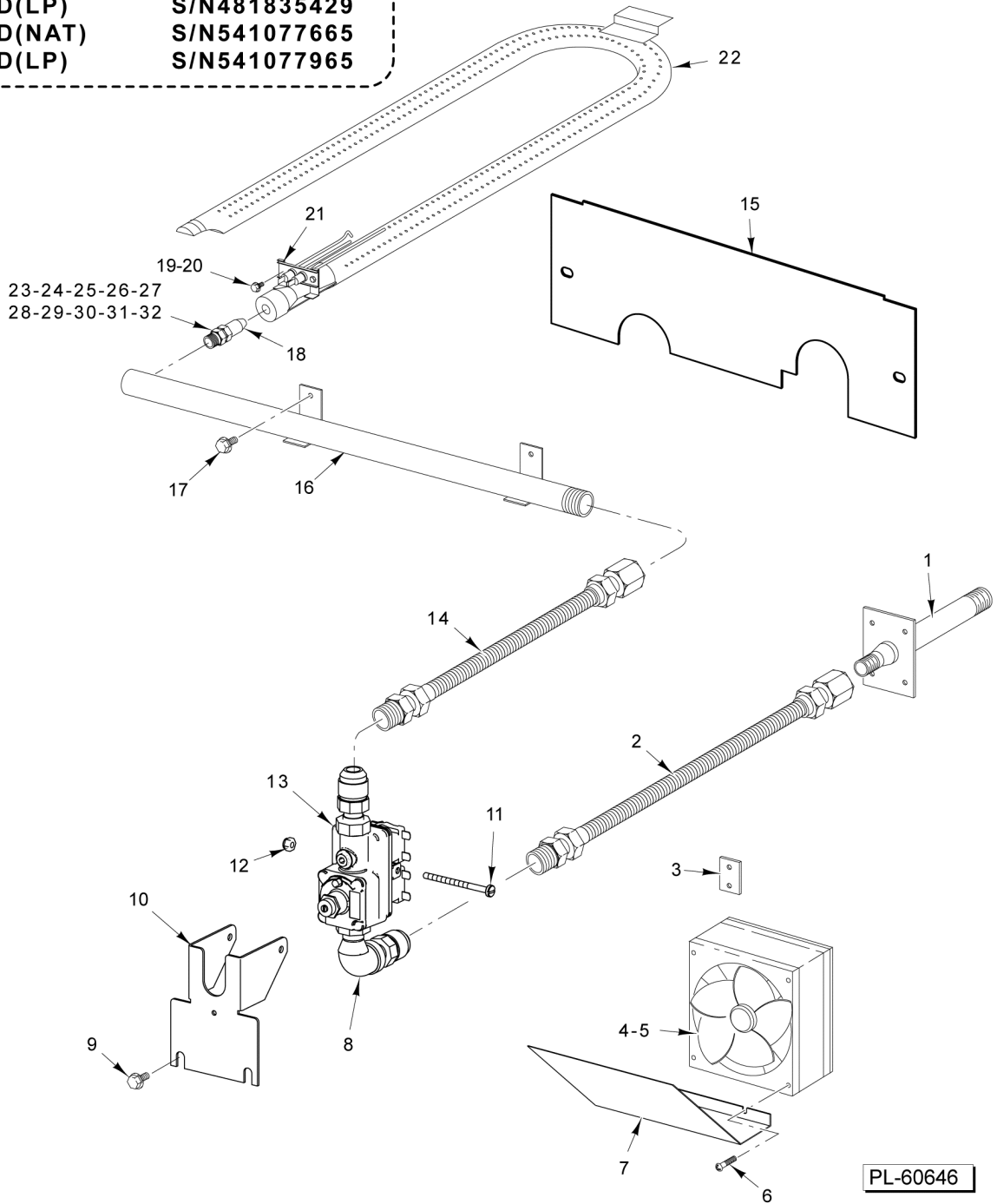

PL-60646

**GAS PIPING AND FLAME CHAMBER
(AFTER SERIAL NUMBER)**

GAS PIPING AND FLAME CHAMBER (AFTER SERIAL NUMBER)

ILLUS. PL-60646	PART NO.	NAME OF PART	AMT.
1	00-423819-00003	Pipe - Weldment Gas Inlet.....	1
2	00-423828-00006	Tube - Flex (30 In.).....	1
3	00-425433-00001	Fan - Clip.....	1
4	00-424940-00001	Fan - Cooling (120 V.).....	1
5	00-424940-00002	Fan - Cooling (230 V.).....	1
6	SD-034-52	Self-Tapping Screw 8-32 x 1 Hex Washer Hd., Type T.....	2
7	00-423820-00001	Deflector - Air.....	1
8	FP-078-75	Elbow - Pipe 3/8 x 90 Deg.....	1
9	SC-113-80	Cap Screw 1/4-20 x 1/2 Hex Hd.....	2
10	00-959486-00001	Bracket - Gas Valve.....	1
11	SC-007-93	Mach. Screw 10-24 X 2-1/2 Slotted Rd. Hd.....	1
12	NS-048-22	Nut, Lock SP. 10-24.....	1
13	00-959662-00001	Valve - Gas, Convertable (NAT & LP).....	1
14	00-423828-00007	Tube - Flex (18 In.).....	1
15	00-959379-00001	Cover - Burner Access, Mid.....	1
16	00-424138-00001	Manifold.....	1
17	SC-113-80	Cap Screw 1/4-20 x 1/2 Hex Hd.....	2
18	00-417879-00001	Nozzle - Pilot Burner.....	1
19	SD-114-24	Mach. Screw 8-32 x 1/2 Phil. Pan Hd.....	2
20	NS-044-07	Nut Assy. 8-32 Hex Keps.....	2
21	00-959507-00001	Igniter - Burner.....	1
22	00-959508-00001	Burner.....	1
23	00-010901-00030	Orifice - Spud (30 Drill) (NAT) (Sea Level to 2499 Ft.).....	1
24	00-010901-00031	Orifice - Spud (31 Drill) (NAT) (2500 Ft. to 3499 Ft.).....	1
25	00-010901-00032	Orifice - Spud (32 Drill) (NAT) (3500 Ft. to 4499 Ft.).....	1
26	00-010901-00032	Orifice - Spud (32 Drill) (NAT) (4500 Ft. to 6499 Ft.).....	1
27	00-010901-00033	Orifice - Spud (33 Drill) (NAT) (6500 Ft. to 8499 Ft.).....	1
28	00-010901-00035	Orifice - Spud (35 Drill) (NAT) (8500 Ft. to 10500 Ft.).....	1
29	00-010901-00046	Orifice - Spud (46 Drill) (LP) (Sea Level to 2499 Ft.).....	1
30	00-010901-00048	Orifice - Spud (48 Drill) (LP) (2500 Ft. to 4499 Ft.).....	1
31	00-010901-00049	Orifice - Spud (49 Drill) (LP) (4500 Ft. to 7499 Ft.).....	1
32	00-010901-00050	Orifice - Spud (50 Drill) (LP) (7500 Ft. to 10500 Ft.).....	1

