

# Parts Catalog



**SP8 Mixer**

## **MIXER**

MODEL: SP8

01-20-15

IMPORTANT!

TO EXPEDITE SHIPMENT OF PARTS, ALWAYS SPECIFY MODEL, REV,  
PART NUMBER, AND SERIAL NUMBER OF MIXER.

## **GLOBE FOOD EQUIPMENT COMPANY**

2215 East River Road

Dayton, Ohio 45439

### **Parts Department**

Toll Free 1-800-745-6238 • Fax (937) 290-0585

E-Mail: [info@globefoodequip.com](mailto:info@globefoodequip.com)

Website: [www.globefoodequip.com](http://www.globefoodequip.com)

Not for resale



# TABLE OF CONTENTS

	Page
Base	1 - 2
Head	3 - 4
Gears	5 - 6
Planetary	7
Wiring Diagram	8

# SP8 BASE COMPONENTS

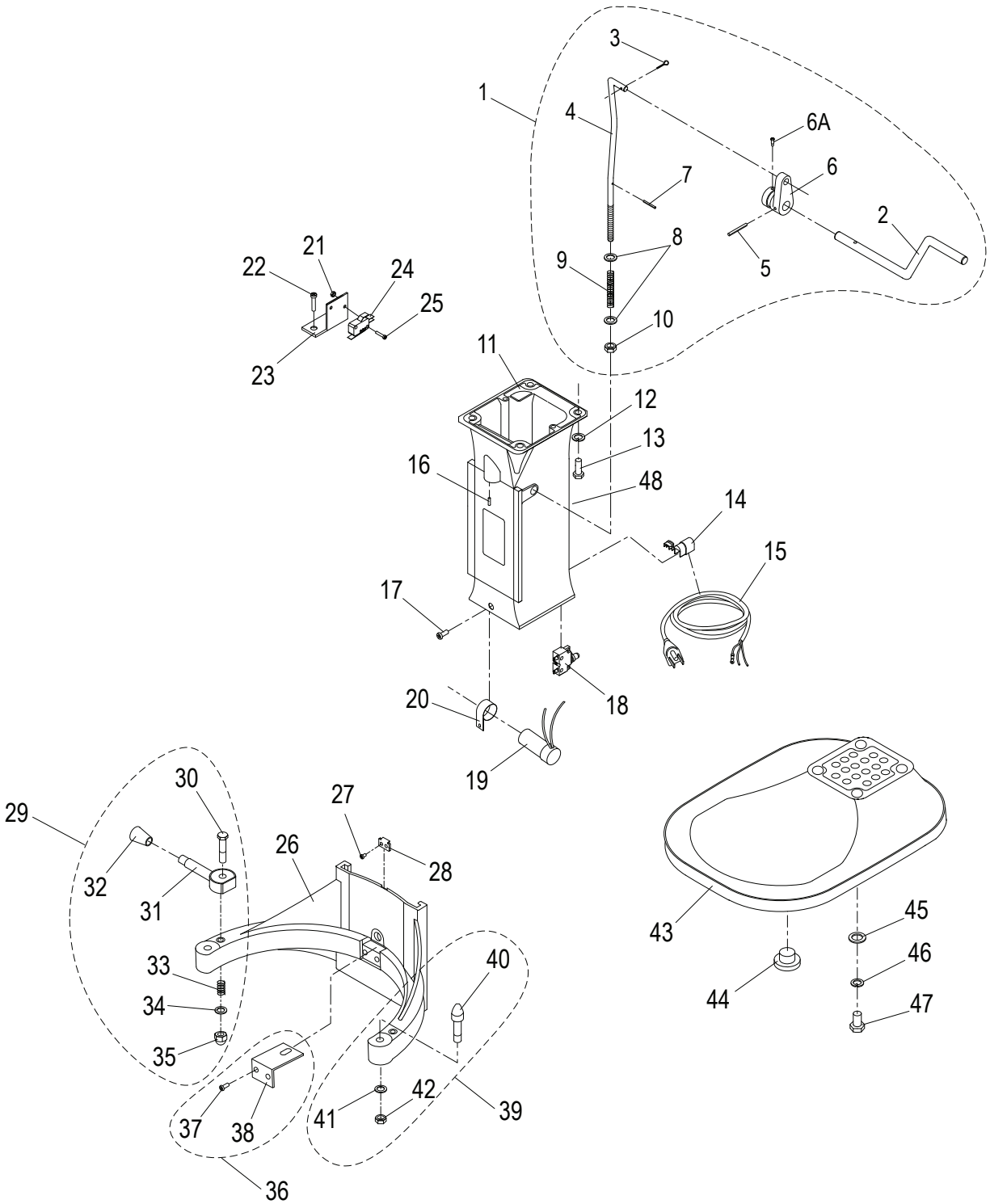

## SP8 BASE PARTS LIST

Item	Description	Part Number	Qty	Hardware
1	Bowl Lift Handle Assembly	X08065-74	1	
2	Handle, Bowl Lift	-	1	
3	Cotter Pin	X08066	1	
4	Rod, Bowl Lift	-	1	
5	Roll Pin	-	1	Ø5x24mm
6	Connector, Bowl Lift	-	1	
6A	Shoulder Screw	X08069A	1	
7	Roll Pin	X08070	1	Ø3x18mm
8	Washer, Flat	X08071	2	M8x16x1.5mm
9	Spring	X08072	1	M5
10	Nut, Hex	X08074	1	M8
11	Mixer Column	X08075	1	
12	Washer, Flat	X08076	4	M8
13	Screw, Hex Head	X08077	4	M8x25mm
14	Strain Relief, 90 Degree	X08078	1	
15	Cord And Plug	X08079	1	
16	Set Screw, Socket Head - Cup Point	X08080	1	M5x20mm
17	Screw, Pan Head	X08081	1	M5x21mm
18	Circuit Breaker	X08082	1	
19	Capacitor, Motor	X08083	1	
20	Bracket, Capacitor Mounting	X08084	1	
21	Nut, Hex	X08155	4	M3
22	Screw, Round Head	X08156	1	M3x24mm
23	Bracket, Microswitch Mtg (W/Hdwr)	X08157	1	
24	Microswitch, Bowl Lift	X08158	1	
25	Screw, Round Head	X08159	2	M3
26	Bowl Cradle	X08086	1	
27	Screw, Pan Head	X08087	2	M4x4mm
28	Clip	X08088	1	
29	Bowl Clamp Assembly (Set/2)	X08089-93	2	
30	Screw, Hex Head & Nuts	X08085	2	M5x45mm
31	Bowl Clamp	-	2	
32	Knob, Plastic	X08090	2	
33	Spring	-	2	
34	Washer, Flat	-	2	M5
35	Nut, Hex	-	2	M5
36	Bowl Lift Bracket Assembly	X08094-95	1	
37	Screw, Pan Head	X08094	2	M5x10mm
38	Bracket, Bowl Lift	X08095	1	
39	Bowl Lock Pin Assembly (Set 2)	X08096-98	1	
40	Pin, Bowl Lock	-	2	
41	Washer, Split Lock	-	2	M8
42	Nut, Stop	-	2	M8
43	Mixer Base	X08099	1	
44	Mixer Feet (Set/4)	X08100	1	
45	Washer, Flat	X08101	4	M8x16mm
46	Washer, Split Lock	X08102	4	M8
47	Screw, Hex Head	X08103	4	M8 x 16mm
48	Label, Hazardous Voltage (Not Shown)	X91014	1	

# SP8 HEAD COMPONENTS

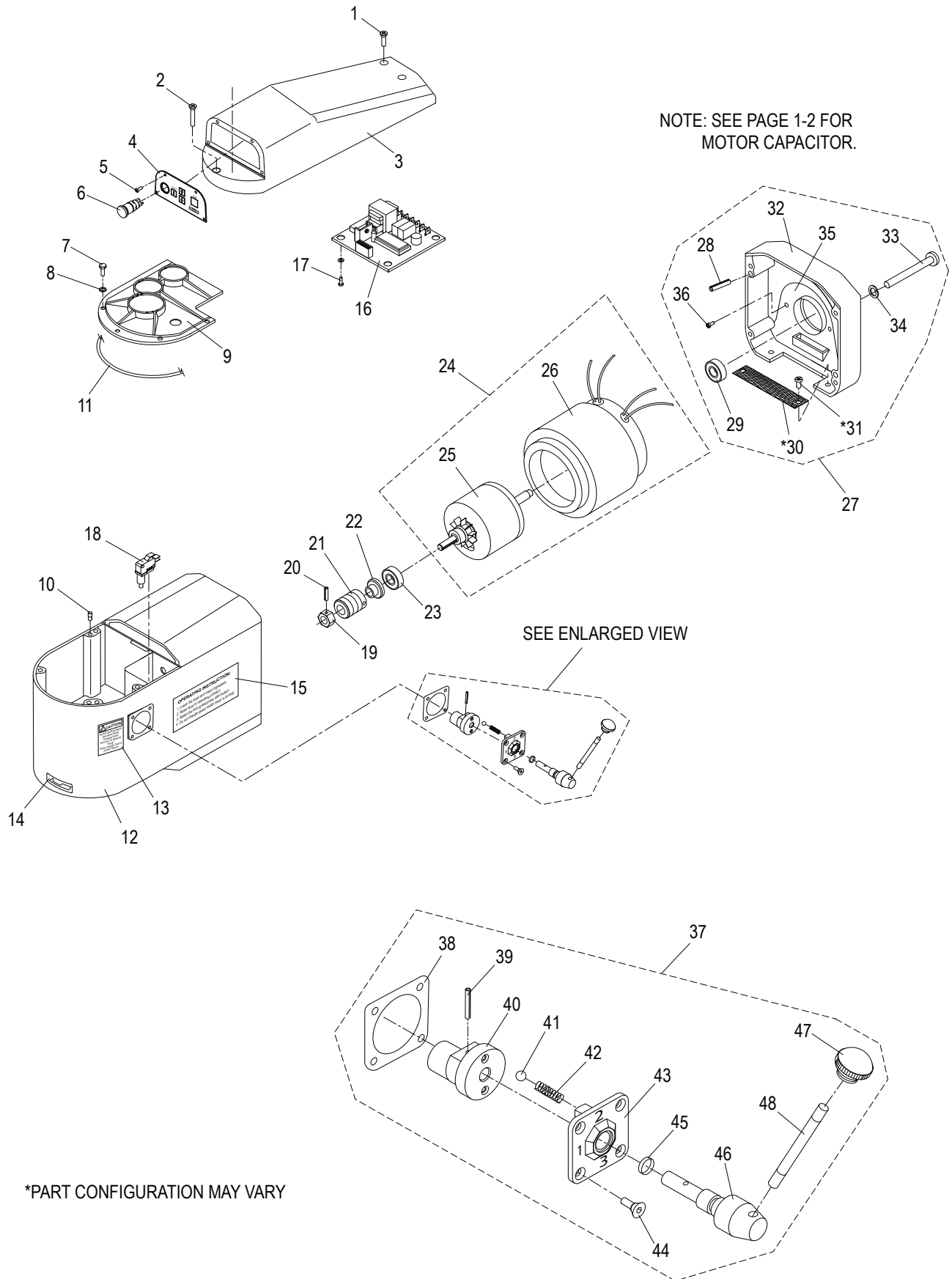

\*PART CONFIGURATION MAY VARY

## SP8 HEAD PARTS LIST

Item	Description	Part Number	Qty	Hardware
1	Screw, Flat Head	X08001	2	M5x20mm
2	Screw, Flat Head	X08002	1	M4x30mm
3	Cover, Transmission	X08003	1	
4	Panel, Digital Control	X08004	1	
5	Screw, Round Head	X08005	4	M3x6mm
6	Emergency Stop Button	X08006	1	
7	Screw, Hex Head	X08007	4	M6x16mm
8	Washer, Split Lock	X08008	4	M6
9	Cover, Transmission Case After S/N 7010674	X08148	1	
	Cover, Transmission Case Prior To S/N 7010675	-	1	
10	Pin, Locator	X08009	2	
11	Gasket	X08148-1	1	
12	Case, Transmission	X08010	1	
13	Label, Stop To Chg Gear	X91010	1	
14	Label, Arrow	X91012	1	
15	Label, Warning	X91007	1	
16	Circuit Board, Digital Control (Includes X08160-1)	X08160	1	
	Circuit Board, Digital Switch	X08160-1	1	
17	Screw, Round Head & Washer - SS	X08161-162	4	M3x10mm
18	Microswitch	X08152	1	
19	Nut, Hex	X08051	4	M10
20	Roll Pin	X08052	1	Ø3x10mm
21	Worm 60Hz	X08053	1	
	Worm 50Hz	X08053-1	1	
22	Oil Seal	X08054	1	
23	Ball Bearing	X08055	1	
24	Motor Assembly After S/N 7010674	X08056-57-1	1	
	Motor Assembly Prior To S/N 7010675	X08056-57		
25	Motor Shaft And Core	-	1	
26	Motor Coil	-	1	
27	Rear Cover Assembly After S/N 7010674	X08058-64	1	
	Rear Cover Assembly Prior To S/N 7010675	-	1	
28	Roll Pin	-	1	Ø6x12mm
29	Ball Bearing	X08059	1	
*30	Screen, Motor Cooling	-	1	
*31	Screw, Pan Head	-	2	M4x6mm
32	Cover, Rear Motor	-	1	
33	Screw, Hex Head & Washer	X08063	4	M5x50mm
34	Washer, Split Lock	-	4	M5
35	Shroud	-	1	
36	Screw, Pan Head	-	3	M3x6mm
37	Gear Arm Assembly	X08040-50	1	
38	Gasket, Gear Arm	X08040	1	
39	Roll Pin	-	1	Ø3x18mm
40	Shaft Bias	-	1	
41	Roller	-	2	
42	Spring	-	2	
43	Plate, Gear Arm	-	1	
44	Screw, Flat Head	X08050	4	
45	O-Ring	-	1	
46	Shaft, Gear Arm	-	1	
47	Knob, Black Plastic	X08046	1	
48	Gear Arm	-	1	

\*Part Configuration May Vary

# SP8 GEARBOX COMPONENTS

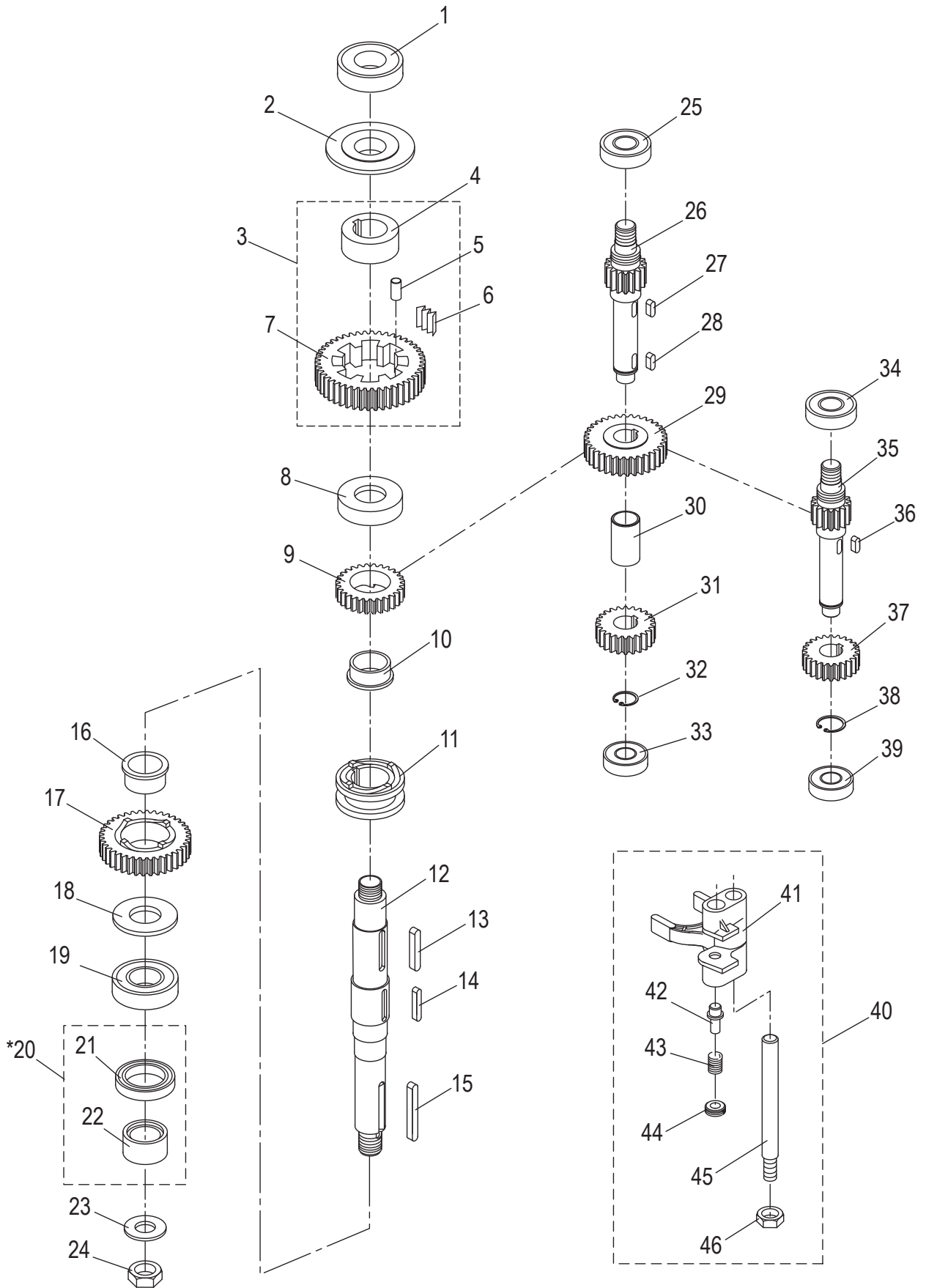



## SP8 GEARBOX PARTS LIST

Item	Description	Part Number	Qty	Hardware
1	Ball Bearing	X08104	1	
2	Lead-In Oil Pad	X08105	1	
3	Slow Speed Gear Assembly	X08106-107	1	
4	Bushing	X08106	1	
5	Roller Pin	-	1	
6	Spring, Slice	-	1	
7	Gear, First Speed (42T)	X08107	1	
8	Bushing	X08108	1	
9	Gear, Clutch (25T)	X08109	1	
10	Bushing, Third Speed	X08110	1	
11	Clutch Sleeve	X08123	1	
12	Drive Shaft	X08124	1	
13	Shaft Key	X08125	1	5x5x18mm
14	Shaft Key	X08126	1	4x4x28mm
15	Shaft Key	X08127	1	5x5x26mm
16	Bushing, Second Speed	X08111	1	
17	Gear, Second Speed (34T)	X08112	1	
18	Bearing Pad	X08113	1	
19	Ball Bearing	X08114	1	
*20	Bushing & Seal Set	X08116-1	1	
21	Oil Seal	-	1	
22	Oil Bushing	-	1	
23	Washer, Flat - SS	X08119	1	M8x22x1mm
24	Nut, Hex - Nylon Insert	X08120	1	M8
25	Ball Bearing	X08128	1	
26	Transmission Shaft (19T)	X08129	1	
27	Shaft Key	X08130	1	5x5x12mm
28	Shaft Key	X08131	1	5x5x14mm
29	Gear, Third Speed (36T)	X08132	1	
30	Bushing, Bronze	X08133	1	
31	Gear, Second Speed (27T)	X08134	1	
32	Retaining Ring	X08135	1	S-15
33	Ball Bearing	X08128	1	
34	Ball Bearing	X08128	1	
35	Master Shaft (18T)	X08143	1	
36	Shaft Key	X08144	1	5x5x14mm
37	Worm Gear, Bronze 60Hz (20T)	X08145	1	
	Worm Gear, Bronze 50Hz (22T)	X08145-1		
38	Retaining Ring	X08135	1	S-15
39	Ball Bearing	X08128	1	
40	Shifter Yoke Assembly	X08137-141	1	
41	Shifter Yoke	-	1	
42	Shifter Yoke Plunger	-	1	
43	Shifter Yoke Spring	-	1	
44	Nut	-	1	M3
45	Shifter Guide Rod	-	1	
46	Nut, Shifter Guide Rod	-	1	

\*Replaces O-Ring Configuration.

# SP8 PLANETARY COMPONENTS

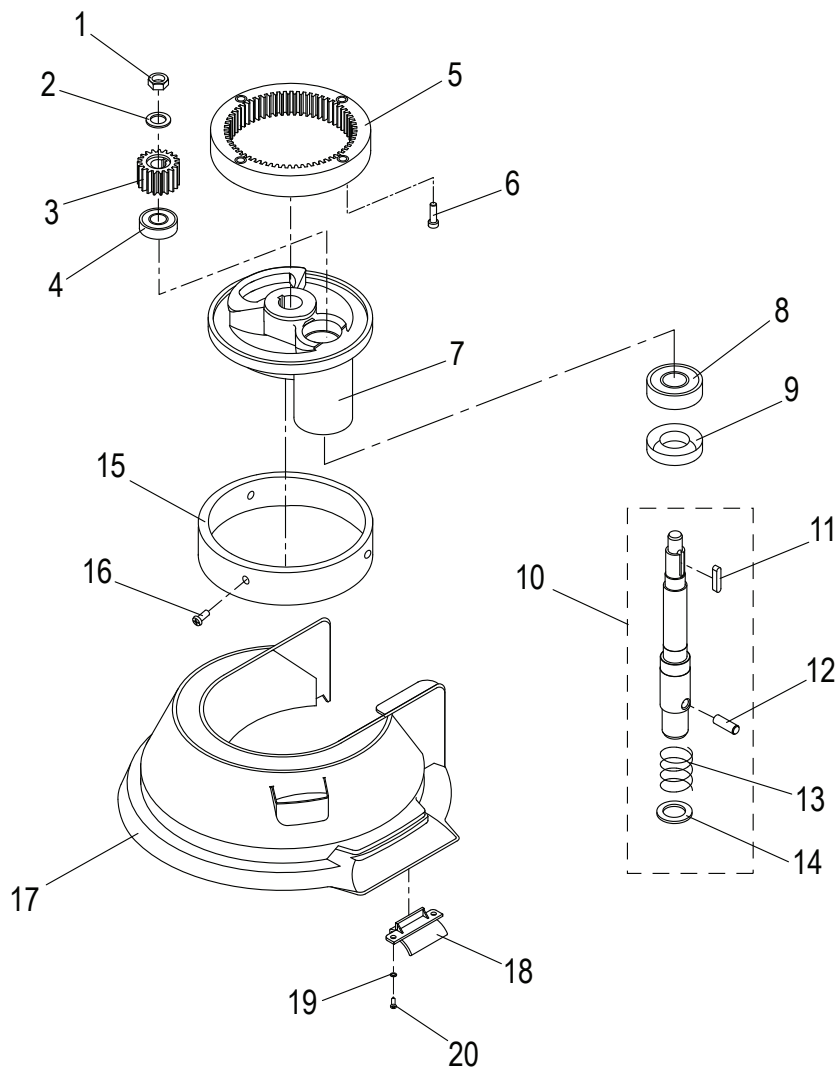

Item	Description	Part Number	Qty	Hardware
1	Nut, Hex - Nylon Insert	X08015	1	M6
2	Washer, Flat	X08016	1	M6x16x1mm
3	Pinion Beater (17T)	X08017	1	
4	Ball Bearing	X08018	1	
5	Planetary Gear (56T)	X08019	1	
6	Cap Screw, Socket Head	X08034	4	M6x13mm
7	Planetary Holder	X08020	1	
8	Ball Bearing	X08022	1	
9	Oil Seal	X08023	1	32X17X7mm
10	Planetary Shaft Assembly	X08024	1	
11	Shaft Key	X08036	1	4x8x8mm
12	Dowel Pin	X08037	1	
13	Spring	X08038	1	
14	Washer, Flat	X08039	1	13.1x1mm
15	Cover, Planetary Holder	X08021	1	
16	Screw, Binder Head	X08035	3	M2.6x4mm
17	Splash Cover, Wire	X08154-1	1	
	Splash Cover, Plastic (W/Clips)	X08154-2	1	
18	Clip	X08149	2	
19	Washer, Flat	X08150	4	M4
20	Screw, Self Tapping Truss Head - Clip Mtg	X08151	4	M4x8mm

# ELECTRICAL DIAGRAM, SP8 MIXER, 120V, 1 PH

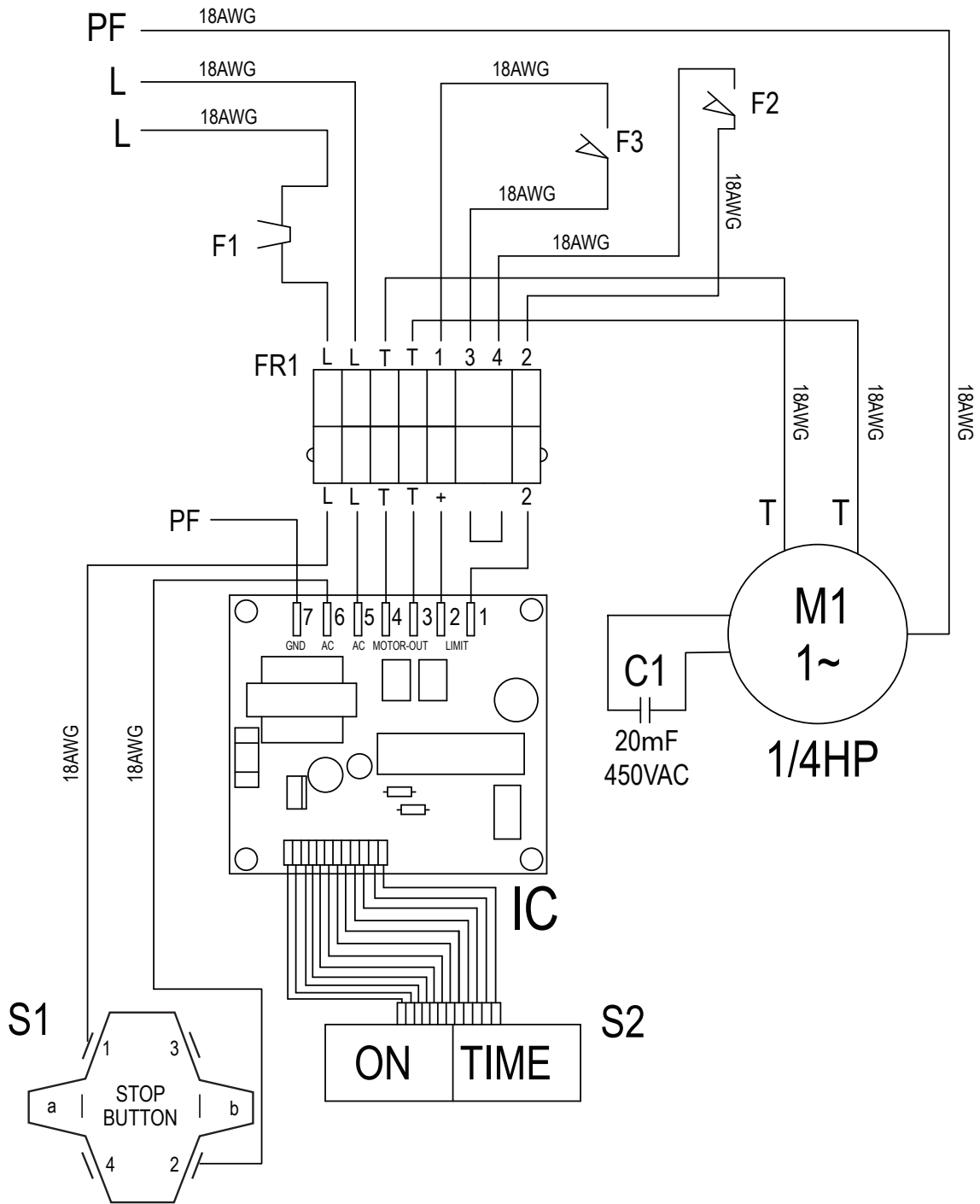

Item	Description	Qty
C1	Capacitor	1
F1	Overload Protection	1
F2	Microswitch (Safety Guard)	1
F3	Microswitch (Bowl Lift)	1
FR1	Terminal Block	1
IC	Ic Board	1
S1	Emergency Stop Button	1
S2	Start Button, Timer LC Control	1
M1	Motor, 1/4HP, 1PH, 120V/220V, 50/60HZ	1

